



MSD

Louisville and Jefferson County Metropolitan Sewer District
700 West Liberty Street
Louisville Kentucky 40203-1911
502-540-6000
www.msdlouky.org

March 7, 2007

Chief, Environmental Enforcement Section
Environmental and Natural Resources Division
U.S. Department of Justice
Post Office Box 7611
Washington DC 20044-7611

Subject: Interim Sanitary Sewer Discharge Plan
Resubmittal
DOJ Case No. 90-5-1-1-08254

Attention Chief:

Please find attached our revised Interim Sanitary Sewer Discharge Plan, prepared in accordance with Paragraph 24.a(2) of our Consent Decree. This plan has been revised in response to review comments received from KDEP and EPA on January 8, 2008.

To aid in your review, we have briefly summarized your comments, and the responses contained in the plan, numbered according to your original sequence.

Comment 1 addressed the issue of "expeditious schedules".

Response 1: The project schedules have been significantly enhanced to clearly illustrate the design, initiation of construction, and completion of construction for each major element. Exhibits 9 through 14 illustrate the revised schedules. In addition, text has been added to Section 3.2 describing the basis for the schedule development. It is important to recognize the inter-relationships between the various elements. Figure 12 has been added to illustrate the order in which project elements must be brought on line to result in a complete and operable system that achieves the performance requirements of the Consent Decree.

Comment 2 addressed the definition of secondary treatment as it relates to wet weather sidestream treatment.

Response 2: After clarifying discussions with EPA and KDEP technical staff, Section 2.5 has been modified. This section now reflects MSD's commitment to provide wet weather treatment that fully meets the definition of secondary treatment, including the requirement for an 85% monthly average removal of BOD5 and TSS, calculated based on the actual days of operation during wet weather. Process modeling has been initiated to confirm unit process sizing and removal efficiency of the original 2 treatment alternatives. In addition, a third alternative has been added that represents an expansion of current secondary treatment processes, and this Alternative 3 is also being modeled at this time. Results of process modeling for all three alternatives will be submitted to KDEP and EPA as part of the Preliminary Engineering Report scheduled for completion in August, 2008. Preliminary modeling results confirm that proper sizing of Alternatives 1 and 3 will result in facilities that are able to meet all the performance parameters that define secondary treatment. Modeling of Alternative 2 has not been completed, but we are less certain of that Alternative's ability to meet all the requirements as we now understand them. If Alternative 2 cannot be proven to achieve the



Beneficial Use of Louisville's Biosolids
www.louisvillegreen.com

performance required, it will be eliminated from further consideration. Figures 9 through 11 are schematic flow charts illustrating the processes currently being evaluated.

Comment 3 states “The Interim SSDP indicates in Section 1, page 7, that most of the problematic service laterals in the Beechwood Village areas have been reconstructed , but the Interim SSDP should also include what steps will be taken to address those which are remaining”

Response 3: The text and word tense has been rewritten to more clearly communicate that it is referring to a past project described for background purposes. Also, the “Beechwood Village Sanitary Sewer Replacement” component of Section 3.2 requires the replacement of all the existing service laterals in Beechwood Village. Therefore the proposed project will remedy any problematic service laterals remaining from previous projects.

Comment 4 requests that “The Interim SSDP should discuss temporary pollution control measures (i.e., filtration and disinfection, etc.) at the overflow points that will be in place while the interim SSDP proposals are being implemented (Sect 2 pg 8)”.

Response 4: MSD will continue to execute their existing procedures at the overflow locations in accordance with the approved SORP while the interim SSDP proposed projects are implemented. Completion of the Interim SSDP projects will prevent further overflows at these locations. No temporary pollution control measures are planned other than those described in the approved SORP.

Comment 5 requests that “The rehabilitation mentioned on pages 5 and 9 in Section 1 should further be described, as well as all other rehabilitation projects outlined in the report”.

Response 5: The text and word tense has been edited at several locations to more clearly communicate that the described projects have been completed. These are not part of the ISSDP response described in Section 2, but descriptions of these projects were included as historical background for the current Interim SSDP.

Comment 6 requests list of acronyms.

Response 6: A list of acronyms has been included following the Table of Contents.

Comment 7 requests a discussion of any follow-up testing to be conducted for assurance of projects’ success, and a description of any further remediation steps that may be implemented if there is still a problem at these SSO discharge locations.

Response 7: Section 3.3 describes the post-construction project assessments to be conducted, including wet weather observation, flow monitoring and modeling, and treatment plant testing. As described in Section 2, the proposed solutions are expected to eliminate discharges at these locations, and no remediation steps have been developed at this time. Remediation steps, if required, will be developed based on the nature of the problem causing them.

Comment 8 requested a solution schematic for the SSO problem in the Carson Way and Ribble Road neighborhood, similar to Figure 3 in Section 1.

Response 8: Figure 7 has been added to Section 2, illustrating the Carson Way and Ribble Road project.

I certify under penalty of law that this document and all attachments were prepared under my direction or supervision in accordance with a system designed to assure that qualified personnel properly gather and evaluate the information submitted. Based on my inquiry of the person or persons who manage the system, or those persons directly responsible for gathering such information, the information submitted is, to the best of my knowledge and belief, true, accurate and complete. I am aware that there are significant penalties for submitting false information, including the possibility of fine and imprisonment for knowing violations.

If you have questions or need additional information, please contact Angela Akridge at (502) 540-6136 or Brian Bingham at (502) 649-3850.

Sincerely,

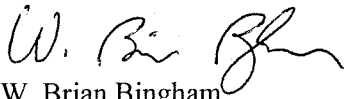

W. Brian Bingham
Regulatory Services Director

cc: H. J. Schardein, Jr.

Paula Purifoy

Laurence J. Zielke



MSD

Louisville and Jefferson County Metropolitan Sewer District
700 West Liberty Street
Louisville Kentucky 40203-1911
502-540-6000
www.msdlouky.org

March 7, 2007

Jeff Cummins, Acting Director
Division of Enforcement
Department of Environmental Protection
14 Reilly Road
Frankfort, KY 40601

Subject: Interim Sanitary Sewer Discharge Plan
Resubmittal
DOJ Case No. 90-5-1-1-08254

Attention Director Cummins:

Please find attached our revised Interim Sanitary Sewer Discharge Plan, prepared in accordance with Paragraph 24.a(2) of our Consent Decree. This plan has been revised in response to review comments received from KDEP and EPA on January 8, 2008.

To aid in your review, we have briefly summarized your comments, and the responses contained in the plan, numbered according to your original sequence.

Comment 1 addressed the issue of "expeditious schedules".

Response 1: The project schedules have been significantly enhanced to clearly illustrate the design, initiation of construction, and completion of construction for each major element. Exhibits 9 through 14 illustrate the revised schedules. In addition, text has been added to Section 3.2 describing the basis for the schedule development. It is important to recognize the inter-relationships between the various elements. Figure 12 has been added to illustrate the order in which project elements must be brought on line to result in a complete and operable system that achieves the performance requirements of the Consent Decree.

Comment 2 addressed the definition of secondary treatment as it relates to wet weather sidestream treatment.

Response 2: After clarifying discussions with EPA and KDEP technical staff, Section 2.5 has been modified. This section now reflects MSD's commitment to provide wet weather treatment that fully meets the definition of secondary treatment, including the requirement for an 85% monthly average removal of BOD5 and TSS, calculated based on the actual days of operation during wet weather. Process modeling has been initiated to confirm unit process sizing and removal efficiency of the original 2 treatment alternatives. In addition, a third alternative has been added that represents an expansion of current secondary treatment processes, and this Alternative 3 is also being modeled at this time. Results of process modeling for all three alternatives will be submitted to KDEP and EPA as part of the Preliminary Engineering Report scheduled for completion in August, 2008. Preliminary modeling results confirm that proper sizing of Alternatives 1 and 3 will result in facilities that are able to meet all the performance parameters that define secondary treatment. Modeling of Alternative 2 has not been completed, but we are less certain of that Alternative's ability to meet all the requirements as we now understand them. If Alternative 2 cannot be proven to achieve the



Beneficial Use of Louisville's Biosolids
www.louisvillegreen.com

performance required, it will be eliminated from further consideration. Figures 9 through 11 are schematic flow charts illustrating the processes currently being evaluated.

Comment 3 states “The Interim SSDP indicates in Section 1, page 7, that most of the problematic service laterals in the Beechwood Village areas have been reconstructed , but the Interim SSDP should also include what steps will be taken to address those which are remaining”

Response 3: The text and word tense has been rewritten to more clearly communicate that it is referring to a past project described for background purposes. Also, the “Beechwood Village Sanitary Sewer Replacement” component of Section 3.2 requires the replacement of all the existing service laterals in Beechwood Village. Therefore the proposed project will remedy any problematic service laterals remaining from previous projects.

Comment 4 requests that “The Interim SSDP should discuss temporary pollution control measures (i.e., filtration and disinfection, etc.) at the overflow points that will be in place while the interim SSDP proposals are being implemented (Sect 2 pg 8)”.

Response 4: MSD will continue to execute their existing procedures at the overflow locations in accordance with the approved SORP while the interim SSDP proposed projects are implemented. Completion of the Interim SSDP projects will prevent further overflows at these locations. No temporary pollution control measures are planned other than those described in the approved SORP.

Comment 5 requests that “The rehabilitation mentioned on pages 5 and 9 in Section 1 should further be described, as well as all other rehabilitation projects outlined in the report”.

Response 5: The text and word tense has been edited at several locations to more clearly communicate that the described projects have been completed. These are not part of the ISSDP response described in Section 2, but descriptions of these projects were included as historical background for the current Interim SSDP.

Comment 6 requests list of acronyms.

Response 6: A list of acronyms has been included following the Table of Contents.

Comment 7 requests a discussion of any follow-up testing to be conducted for assurance of projects’ success, and a description of any further remediation steps that may be implemented if there is still a problem at these SSO discharge locations.

Response 7: Section 3.3 describes the post-construction project assessments to be conducted, including wet weather observation, flow monitoring and modeling, and treatment plant testing. As described in Section 2, the proposed solutions are expected to eliminate discharges at these locations, and no remediation steps have been developed at this time. Remediation steps, if required, will be developed based on the nature of the problem causing them.

Comment 8 requested a solution schematic for the SSO problem in the Carson Way and Ribble Road neighborhood, similar to Figure 3 in Section 1.

Response 8: Figure 7 has been added to Section 2, illustrating the Carson Way and Ribble Road project.

I certify under penalty of law that this document and all attachments were prepared under my direction or supervision in accordance with a system designed to assure that qualified personnel properly gather and evaluate the information submitted. Based on my inquiry of the person or persons who manage the system, or those persons directly responsible for gathering such information, the information submitted is, to the best of my knowledge and belief, true, accurate and complete. I am aware that there are significant penalties for submitting false information, including the possibility of fine and imprisonment for knowing violations.

If you have questions or need additional information, please contact Angela Akridge at (502) 540-6136 or Brian Bingham at (502) 649-3850.

Sincerely,

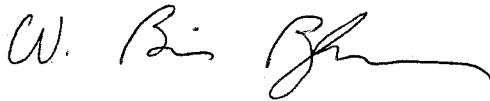
A handwritten signature in black ink, appearing to read "W. Brian Bingham". The signature is fluid and cursive, with the first name "W." and last name "Bingham" clearly legible.

W. Brian Bingham
Regulatory Services Director

cc: H. J. Schardein, Jr.

Paula Purifoy

Laurence J. Zielke



MSD

Louisville and Jefferson County Metropolitan Sewer District
700 West Liberty Street
Louisville Kentucky 40203-1911
502-540-6000
www.msdlouky.org

March 7, 2007

Chief, Water Programs Enforcement Branch
Water Management Program
US EPA Region 4
Atlanta Federal Center
61 Forsyth Street SW
Atlanta, GA 30303

Subject: Interim Sanitary Sewer Discharge Plan
Resubmittal
DOJ Case No. 90-5-1-1-08254

Attention Chief:

Please find attached our revised Interim Sanitary Sewer Discharge Plan, prepared in accordance with Paragraph 24.a(2) of our Consent Decree. This plan has been revised in response to review comments received from KDEP and EPA on January 8, 2008.

To aid in your review, we have briefly summarized your comments, and the responses contained in the plan, numbered according to your original sequence.

Comment 1 addressed the issue of "expeditious schedules".

Response 1: The project schedules have been significantly enhanced to clearly illustrate the design, initiation of construction, and completion of construction for each major element. Exhibits 9 through 14 illustrate the revised schedules. In addition, text has been added to Section 3.2 describing the basis for the schedule development. It is important to recognize the inter-relationships between the various elements. Figure 12 has been added to illustrate the order in which project elements must be brought on line to result in a complete and operable system that achieves the performance requirements of the Consent Decree.

Comment 2 addressed the definition of secondary treatment as it relates to wet weather sidestream treatment.

Response 2: After clarifying discussions with EPA and KDEP technical staff, Section 2.5 has been modified. This section now reflects MSD's commitment to provide wet weather treatment that fully meets the definition of secondary treatment, including the requirement for an 85% monthly average removal of BOD5 and TSS, calculated based on the actual days of operation during wet weather. Process modeling has been initiated to confirm unit process sizing and removal efficiency of the original 2 treatment alternatives. In addition, a third alternative has been added that represents an expansion of current secondary treatment processes, and this Alternative 3 is also being modeled at this time. Results of process modeling for all three alternatives will be submitted to KDEP and EPA as part of the Preliminary Engineering Report scheduled for completion in August, 2008. Preliminary modeling results confirm that proper sizing of Alternatives 1 and 3 will result in facilities that are able to meet all the performance parameters that define secondary treatment. Modeling of Alternative 2 has not been completed, but we are less certain of that Alternative's ability to meet all the



Beneficial Use of Louisville's Biosolids
www.louisvillegreen.com

requirements as we now understand them. If Alternative 2 cannot be proven to achieve the performance required, it will be eliminated from further consideration. Figures 9 through 11 are schematic flow charts illustrating the processes currently being evaluated.

Comment 3 states “The Interim SSDP indicates in Section 1, page 7, that most of the problematic service laterals in the Beechwood Village areas have been reconstructed , but the Interim SSDP should also include what steps will be taken to address those which are remaining”

Response 3: The text and word tense has been rewritten to more clearly communicate that it is referring to a past project described for background purposes. Also, the “Beechwood Village Sanitary Sewer Replacement” component of Section 3.2 requires the replacement of all the existing service laterals in Beechwood Village. Therefore the proposed project will remedy any problematic service laterals remaining from previous projects.

Comment 4 requests that “The Interim SSDP should discuss temporary pollution control measures (i.e., filtration and disinfection, etc.) at the overflow points that will be in place while the interim SSDP proposals are being implemented (Sect 2 pg 8)”.

Response 4: MSD will continue to execute their existing procedures at the overflow locations in accordance with the approved SORP while the interim SSDP proposed projects are implemented. Completion of the Interim SSDP projects will prevent further overflows at these locations. No temporary pollution control measures are planned other than those described in the approved SORP.

Comment 5 requests that “The rehabilitation mentioned on pages 5 and 9 in Section 1 should further be described, as well as all other rehabilitation projects outlined in the report”.

Response 5: The text and word tense has been edited at several locations to more clearly communicate that the described projects have been completed. These are not part of the ISSDP response described in Section 2, but descriptions of these projects were included as historical background for the current Interim SSDP.

Comment 6 requests list of acronyms.

Response 6: A list of acronyms has been included following the Table of Contents.

Comment 7 requests a discussion of any follow-up testing to be conducted for assurance of projects’ success, and a description of any further remediation steps that may be implemented if there is still a problem at these SSO discharge locations.

Response 7: Section 3.3 describes the post-construction project assessments to be conducted, including wet weather observation, flow monitoring and modeling, and treatment plant testing. As described in Section 2, the proposed solutions are expected to eliminate discharges at these locations, and no remediation steps have been developed at this time. Remediation steps, if required, will be developed based on the nature of the problem causing them.

Comment 8 requested a solution schematic for the SSO problem in the Carson Way and Ribble Road neighborhood, similar to Figure 3 in Section 1.

Response 8: Figure 7 has been added to Section 2, illustrating the Carson Way and Ribble Road project.

I certify under penalty of law that this document and all attachments were prepared under my direction or supervision in accordance with a system designed to assure that qualified personnel properly gather and evaluate the information submitted. Based on my inquiry of the person or persons who manage the system, or those persons directly responsible for gathering such information, the information submitted is, to the best of my knowledge and belief, true, accurate and complete. I am aware that there are significant penalties for submitting false information, including the possibility of fine and imprisonment for knowing violations.

If you have questions or need additional information, please contact Angela Akridge at (502) 540-6136 or Brian Bingham at (502) 649-3850.

Sincerely,

A handwritten signature in black ink, appearing to read "W. Brian Bingham". The signature is fluid and cursive, with the first name "W." and last name "Bingham" clearly visible.

W. Brian Bingham
Regulatory Services Director

cc: H. J. Schardein, Jr.

Paula Purifoy

Laurence J. Zielke



MSD

Louisville and Jefferson County
Metropolitan Sewer District

Interim Sanitary Sewer Discharge Plan (ISSDP)

March 8, 2008

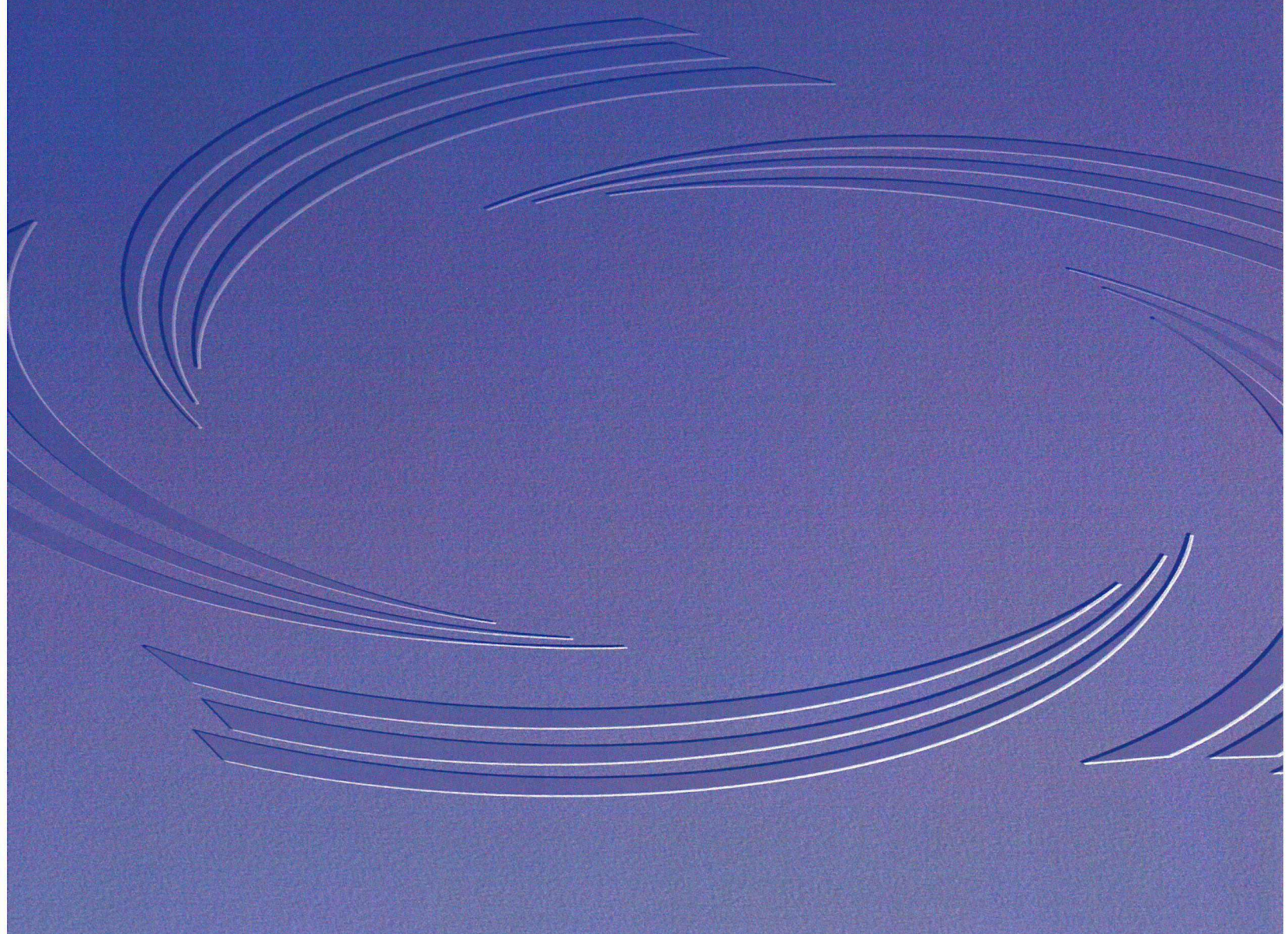



EXECUTIVE SUMMARY Page 1

SECTION 1: TARGETED UNAUTHORIZED DISCHARGES: BACKGROUND, PROBLEM DEFINITION, MITIGATION TO-DATE, AND EVALUATED ALTERNATIVES Page 1

1.1. Middle Fork / Beechwood Village Area Page 4

 1.1.1. Middle Fork / Beechwood Village Previous Studies Page 5

 1.1.2. Middle Fork / Beechwood Village Hydraulic Modeling Page 6

 1.1.3. Middle Fork / Beechwood Village Previous Construction Work Page 6

 1.1.4. Middle Fork / Beechwood Village Evaluated Alternatives Page 7

1.2. Hikes Point Area and Highgate Springs Pump Station Page 8

 1.2.1. Hikes Point Area Previous Studies Page 9

 1.2.2. Hikes Point Area Hydraulic Modeling Page 10

 1.2.3. Hikes Point Previous Construction Work Page 10

 1.2.4. Hikes Point Evaluated Alternatives Page 11

1.3. Southeast Diversion Structure / Pond Creek Area Page 15

 1.3.1. Pond Creek Previous Studies Page 16

 1.3.2. Pond Creek Hydraulic Modeling Page 17

 1.3.3. Southeast Diversion / Pond Creek Previous Capacity Assessments
 and Evaluated Alternatives Page 17

 1.3.4. Southeast Diversion / Pond Creek Boundary Conditions Page 18

1.4. West County Wastewater Treatment Plant Background Page 19

 1.4.1. West County Wastewater Treatment Plant Hydraulic Modeling Page 19

 1.4.2. West County Wastewater Treatment Plant Previous Capacity
 Assessments And Evaluated Alternatives Page 19

SECTION 2: THE ISSDP SOLUTION Page 1

2.1. Middle Fork / Beechwood Village Recommended Solution Page 1

2.2. Hikes Point / Highgate Springs Pump Station Recommended Solution Page 1

2.3. Southeast Diversion Recommended Solution Page 4

2.4. Northern Ditch Recommended Solution Page 7

2.5. WCWTP Recommended Solution Page 7

 Technical Paper: "The Role Of Activated Sludge Solids In An Actiflo® System"

 Technical Paper: "Full Scale High Rate Wet Weather Biological Contact Performance"

SECTION 3: IMPLEMENTATION PLAN Page 1

3.1. Preliminary Capital Cost Estimates Page 1

3.2. Preliminary Project Schedules Page 3

 3.2.1. General Page 3



3.2.2	Easements and Property Acquisitions.....	Page 3
3.2.3	U.S. Army Corps of Engineers.....	Page 5
3.2.4	Kentucky Division of Water Construction Permit Review.....	Page 5
3.2.5	Advertise, Bid and Award.....	Page 5
3.2.6	Project 1: Beechwood Village Sanitary Sewer Replacement.....	Page 6
3.2.7	Project 2: Sinking Fork Relief Sewer.....	Page 6
3.2.8	Project 3: Hikes Point Interceptor and HSPS.....	Page 7
3.2.9	Project 4: Southeast (SE) Diversion and Interceptor.....	Page 8
3.2.10	Project 5: Northern Ditch Diversion Interceptor Sewer.....	Page 9
3.2.11	Project 6: WCWTP Wastewater Flow Equalization and Treatment.....	Page 10
3.3	Project Assessment.....	Page 10

TABLES

Table ES 1:	Estimated Cost to Implement the ISSDP
Table 1:	Beechwood Village Temporary Pump Locations, Average Annual Discharge Frequency and Volume (2002-2006)
Table 2:	Hikes Point Temporary Pump Locations, Average Annual Discharge Frequency and Volume (2002-2006)
Table 3:	Preliminary Design Criteria for Proposed Secondary Treatment Facilities at WCWTP
Table 4:	Estimated Cost to Implement the ISSDP

FIGURES

Figure ES 1:	Recommended ISSDP Solution
Figure ES 2:	Comprehensive ISSDP Implementation Schedule
Figure 1:	Unauthorized Discharge Relationships
Figure 2:	Southeast Diversion Structure
Figure 3:	Hikes Point System Improvements Alternatives
Figure 4:	Conveyance of Flows through Hikes Point
Figure 5:	Beechwood Village System Improvements Phasing Plan
Figure 6:	Proposed Hikes Lane Interceptor
Figure 7:	Carson Way and Ribble Road – Proposed Improvement Alternatives
Figure 8:	Proposed Southeast Diversion Modification
Figure 9:	Alternative 1 – High Rate Secondary Treatment – Process Flow Diagram
Figure 10:	Alternative 2 – Biological Filters – Process Flow Diagram
Figure 11:	Alternative 3 – Conventional Treatment – Process Flow Diagram
Figure 12:	Project Sequence and Schematics



MSD

Louisville and Jefferson County
Metropolitan Sewer District

Interim Sanitary Sewer Discharge Plan (ISSDP)

March 8, 2008

EXHIBITS

- Exhibit 1: Targeted Unauthorized Discharge Locations
- Exhibit 2: Recommended ISSDP Solution
- Exhibit 3: Beechwood Village Area
- Exhibit 4: Highgate Springs Pump Station Area
- Exhibit 5: Hikes Point Area
- Exhibit 6: Southeast Diversion Structure
- Exhibit 7: Northern Ditch Area
- Exhibit 8: West County Wastewater Treatment Plant
- Exhibit 9: Beechwood Village System Improvements Schedule
- Exhibit 10: Sinking Fork Relief Sewer Schedule
- Exhibit 11: Hikes Pt Interceptor and Highgate Springs PS Schedule
- Exhibit 12: Southeastern Diversion and Interceptor Schedule
- Exhibit 13: Northern Ditch Diversion Interceptor Schedule
- Exhibit 14: West County Treatment Plant Schedule

**ACRONYMS**

alum	Aluminum Sulfate: $Al_2(SO_4)_3$
BGI	Beargrass Interceptor
BOD ₅	5 day Biochemical Oxygen Demand
cfs	Cubic Feet per Second
CIPP	Cured-In-Place Pipe
CSO	Combined Sewer Overflow
CSS	Combined Sewer System
ENR	Engineering News Record
EPA	Environmental Protection Agency
FELL-41	Focused Electrode Leak Locator
HEC RAS	Hydraulic water flow modeling software
HSPS	Highgate Springs Pump Station
I/I	Infiltration and Inflow
ISSDP	Interim Sanitary Sewer Discharge Plan
KDEP	Kentucky Department of Environmental Protection
KDOW	Kentucky Department of Water
KPDES	Kentucky Pollutant Discharge Elimination System
LF	Linear Feet
MFWTP	Morris Forman Wastewater Treatment Plant
MG	Million Gallons
MGD	Million Gallons per Day
mg / L	milligrams per Liter
MH	Manhole
MLSS	Mixed Liquor Suspended Solids
MSD	Louisville and Jefferson County Metropolitan Sewer District
NDI	North Ditch Interceptor
NDDI	Northern Ditch Diversion Interceptor
N	Nitrogen
NH ₃	Ammonia
PS	Pump Station
PSC	Property Service Connection
PVC	Polyvinyl Chloride
RTC	Real Time Control



MSD

Louisville and Jefferson County
Metropolitan Sewer District

**Interim Sanitary Sewer Discharge Plan (ISSDP)
March 8, 2008**

SED	Southeast Diversion Structure
SEI Relief	Southeastern Interceptor Relief sewer
SORP	Sewer Overflow Response Protocol
SS	Sanitary Sewer
SSES	Sanitary Sewer Evaluation Study
SSO	Sanitary Sewer Overflow
TMDL	Total Maximum Daily Load
TSS	Total Suspended Solids
VCP	Vitrified Clay Pipe
WCWTP	West County Wastewater Treatment Plant
WTP	Wastewater Treatment Plant
WWP	Wet Weather Program
XP-SWMM	Storm Water Management Modeling Software



MSD

Louisville and Jefferson County
Metropolitan Sewer District

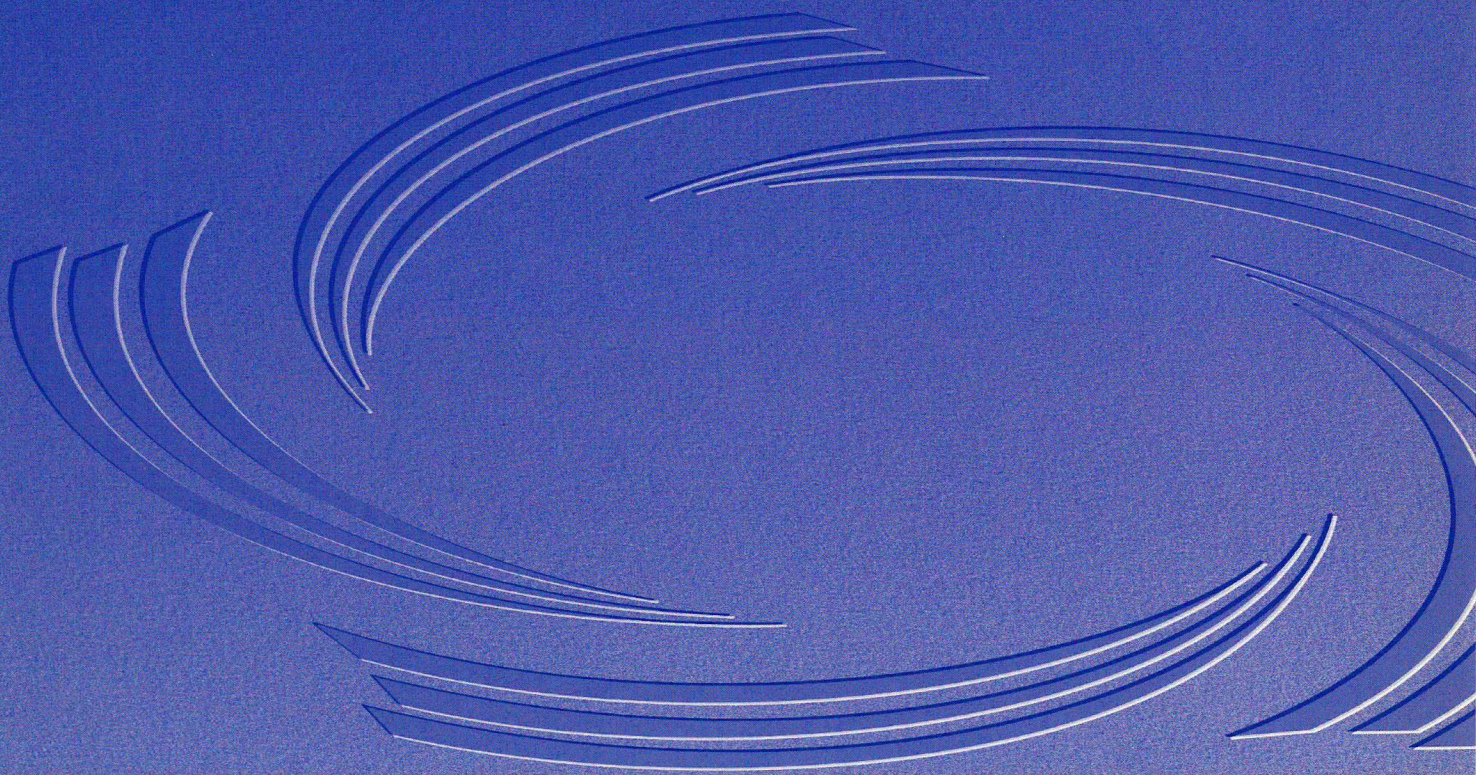

Interim Sanitary Sewer Discharge Plan



EXECUTIVE SUMMARY

In accordance with the Louisville and Jefferson County Metropolitan Sewer District's (MSD's) Consent Decree entered into Federal court on August 12, 2005, MSD is submitting the attached Interim Sanitary Sewer Discharge Plan (ISSDP) to the Kentucky Department of Environmental Protection (KDEP) and the Environmental Protection Agency (EPA) for approval.

The ISSDP presents the proposed plan for eliminating targeted unauthorized discharges in MSD's wastewater collection system. The ISSDP will accomplish the following objectives:

- Eliminate the use of pumps in the Beechwood Village Area
- Eliminate the use of pumps in the Hikes Point Area
- Eliminate the Highgate Springs Pump Station
- Eliminate the constructed overflow at the Southeast Diversion Structure

MSD has developed an integrated design concept to eliminate the targeted unauthorized discharges for these locations as outlined in the Consent Decree. The ISSDP details the history of the problem areas and presents the final solution for eliminating the unauthorized discharges. The ISSDP is organized in three sections that present the overall problem and solutions as intended in the ISSDP.

A summary of the sections follows:

Section 1 provides a comprehensive overview of the targeted areas and includes area maps, tables, and figures. Problem definitions are detailed for the four targeted areas as well as background information about land use, population, soils, and sewer lines, as appropriate. Also detailed is an overview of previous activities, such as studies, hydraulic modeling, construction projects, and various infiltration and inflow (I/I) remediation projects. In addition, each of the four targeted area sections concludes with a capacity analysis and lists previously evaluated mitigation alternatives.

Section 2 identifies corrective measures necessary for eliminating the unauthorized discharges. The solutions incorporate a holistic design concept, given the findings from previous studies, various sewer rehabilitation projects, sewer system capacity assessment projects, sewer system flow monitoring, and computer modeling efforts.

Maps, exhibits, tables, and figures are used throughout the ISSDP to provide a comprehensive outline of the solutions. Moreover, the ISSDP describes the design concepts for preliminary sewer routes, and the conceptual schematic for the wet weather treatment facilities at West County Wastewater Treatment Plant (WCWTP). The locations of the major components of the ISSDP Solution are shown in Figure ES 1.

Eliminating the unauthorized discharges at the targeted locations will capture more flow in the separate sewer system that will eventually need to be treated. As a result, a new flow control structure will be added to the Northern Ditch Interceptor, and some or all of the wet weather flows received at the flow control structure will be diverted to the WCWTP. As a component of the solution, a system that includes a new interceptor, on-site flow equalization, and wet

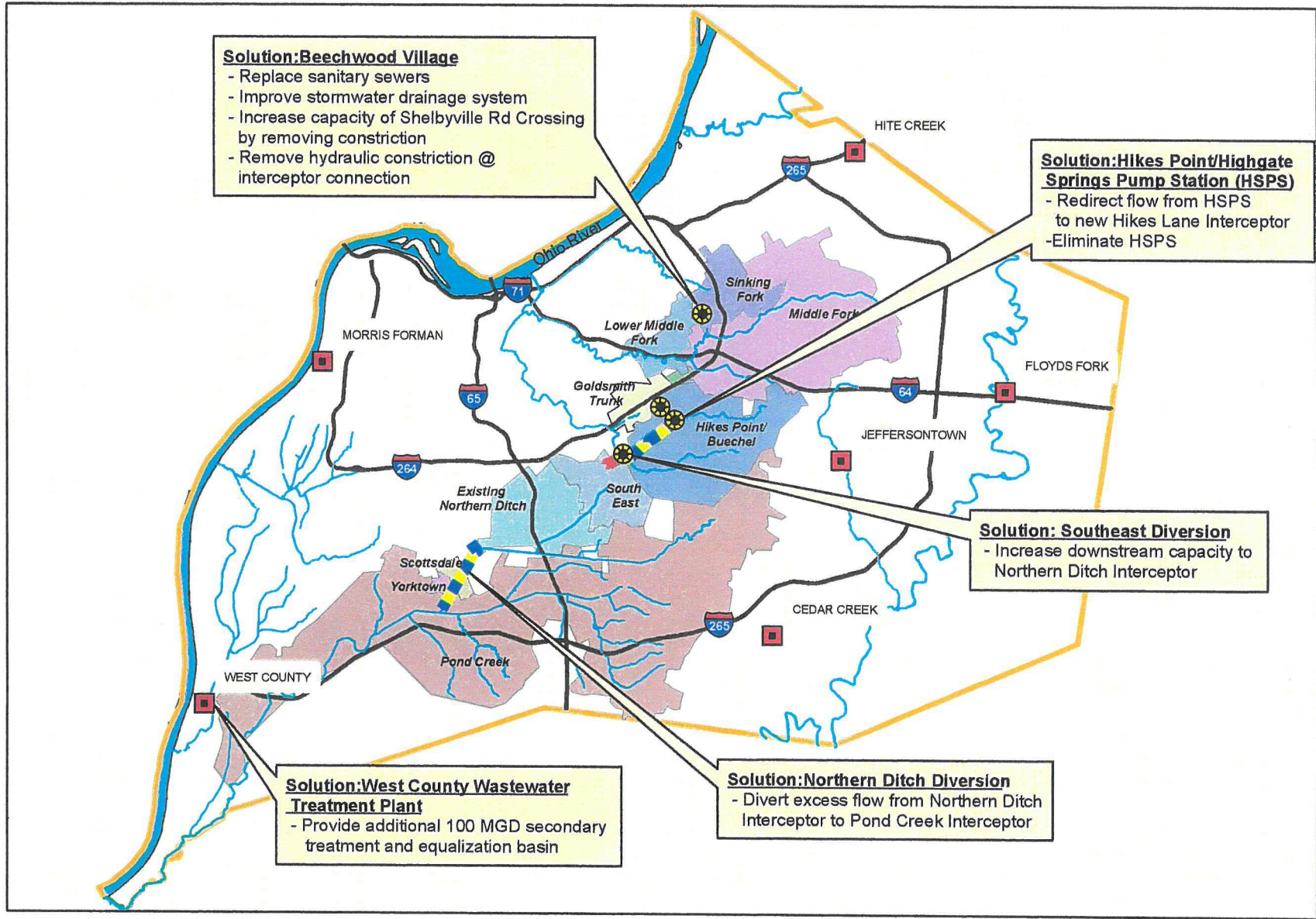

Figure ES 1: Recommended ISSDP Solution



Legend

- Targeted Overflows
- Major Stream
- INTERSTATE
- WTP
- County Boundary



weather treatment at the existing WCWTP site will be used to manage wet weather flows and treat them in compliance with discharge permit parameters.

Following are some of the solution elements:

- Reconstruction of the Beechwood Village sanitary sewer system;
- Elimination of a flow restriction in the Sinking Fork Interceptor;
- Increase conveyance from the Carson Way and Ribble Road pumped unauthorized discharge to the existing Goldsmith Trunk Sewer;
- Decommission the Highgate Springs Pump Station by intercepting influent flows in a new relief sewer that runs from the intersection of Hikes Lane and the South Fork of Beargrass Creek to the Southeast Diversion Structure;
- Increase conveyance capacity from the four pumped unauthorized discharge locations in the Hikes Point area to the existing Hike's Point branch of the Beargrass Interceptor;
- Increase conveyance between Southeast Diversion Structure and the Northern Ditch Interceptor;
- Divert wet weather flows from the Northern Ditch Interceptor to the Pond Creek Interceptor (New Northern Ditch Diversion Interceptor);
- Provide flow equalization and additional secondary treatment facilities at WCWTP.

Section 3 presents the preliminary capital costs and implementation schedule. The capital cost to implement the ISSDP is approximately \$200 million, as shown in Table ES 1. MSD must implement the corrective measures necessary for remediation of the unauthorized discharges in the Beechwood Village area and at the Southeast Diversion Structure by December 31, 2011. Similarly, the unauthorized discharges at Hikes Point and Highgate Springs Pump Station must be eliminated by December 31, 2013. The proposed implementation schedule to achieve these dates is shown in Figure ES 2.

TABLE ES 1		
ESTIMATED COST TO IMPLEMENT THE ISSDP		
PROJECT AREA	DESCRIPTION	COST
BEECHWOOD VILLAGE		
Beechwood Village System Improvements	Install 25,000 LF of New 8-inch Pipe Replace Existing 8-inch and 12-inch Pipes Replace 580 PSCs and Cleanouts Install 125 New Manholes	\$14,100,000
Sinking Fork Relief Sewer	Install 2000 LF of New 15-inch Pipe	\$1,800,000
TOTAL PROJECT CAPITAL COST		\$15,900,000
HIKES POINT & HIGHGATE SPRINGS PUMP STATION		
Hikes Lane Interceptor	Install 10,000 LF of New 72-inch Pipe Decommission Highgate Springs PS	\$28,900,000
Hikes Point Collection System	Install 2500 LF of New 21-inch Pipe	\$2,600,000
Carson / Ribble SSO Elimination	Install 1000 LF of New 15-, 18-, and 24-inch Pipe	\$200,000
TOTAL PROJECT CAPITAL COST		\$31,700,000
SOUTHEAST DIVERSION		
Southeast Diversion Modifications	Remove Weirs Re-program RTC gates	\$100,000
Southeastern Relief Interceptor	Install 3100 LF of New 36-inch Pipe Install Flow Control Junction Box	\$2,100,000
TOTAL PROJECT CAPITAL COST		\$ 2,200,000
NORTHERN DITCH DIVERSION		
Northern Ditch Diversion Interceptor	Install 13,000 LF of New 84-inch Pipe	\$24,700,000
TOTAL PROJECT CAPITAL COST		\$24,700,000
WEST COUNTY WASTEWATER TREATMENT PLANT		
High-rate Treatment	Construct 100 MGD High-Rate Secondary Treatment	\$87,800,000
Pump Station Modifications	Expand from 80 MGD Firm to 291 MGD Firm	\$10,700,000
Screen / Concrete Basin	Construct 200 MGD with 30 min. Detention	\$20,400,000
Equalization Basin	Construct 36 MG Earthen Basin	\$3,100,000
TOTAL PROJECT CAPITAL COST		\$122,000,000
TOTAL SOLUTION COST		\$196,500,000

Figure ES 2

InterIm Sanitary Sewer Discharge Plan

Implementation Schedule

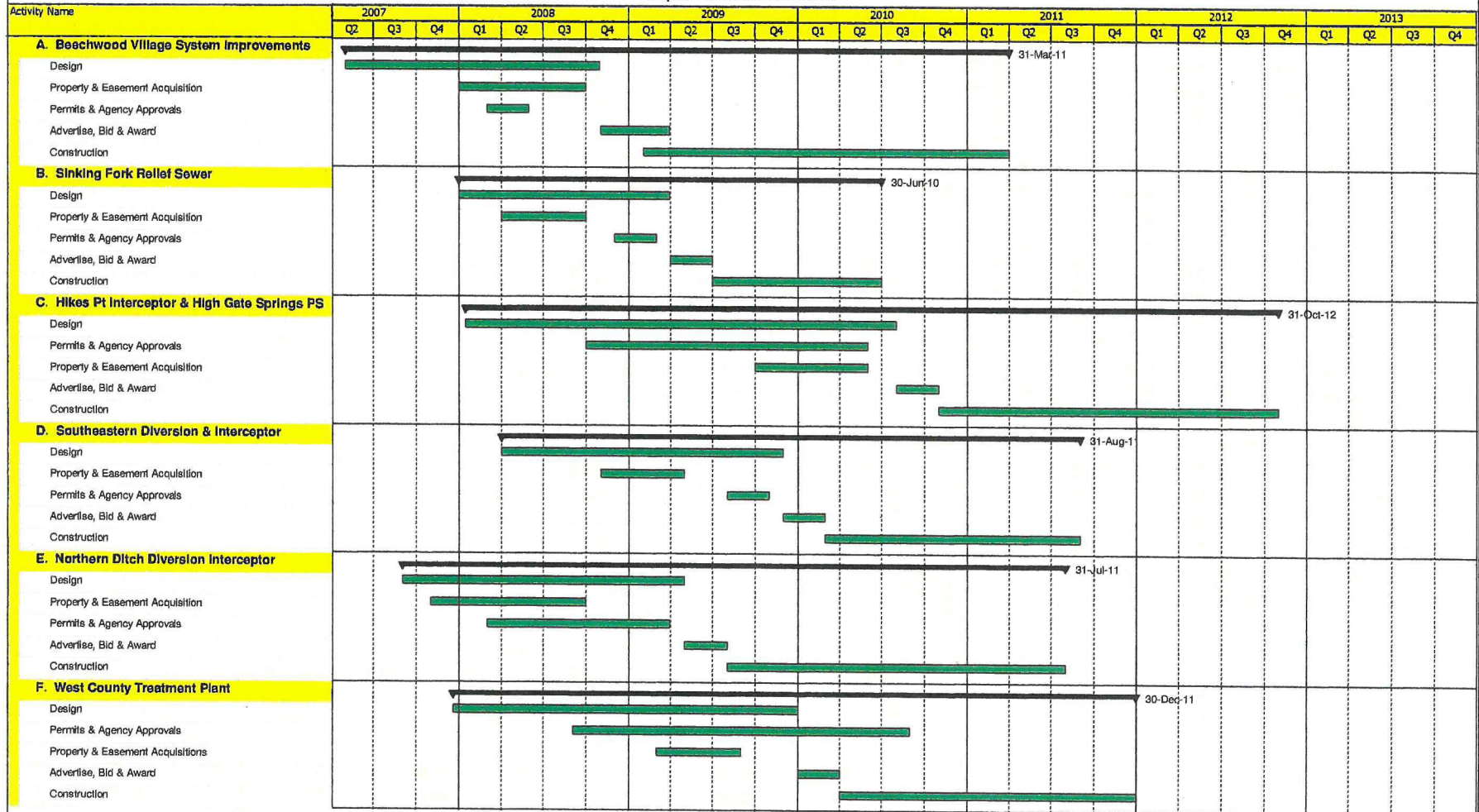



MSD

Louisville and Jefferson County
Metropolitan Sewer District

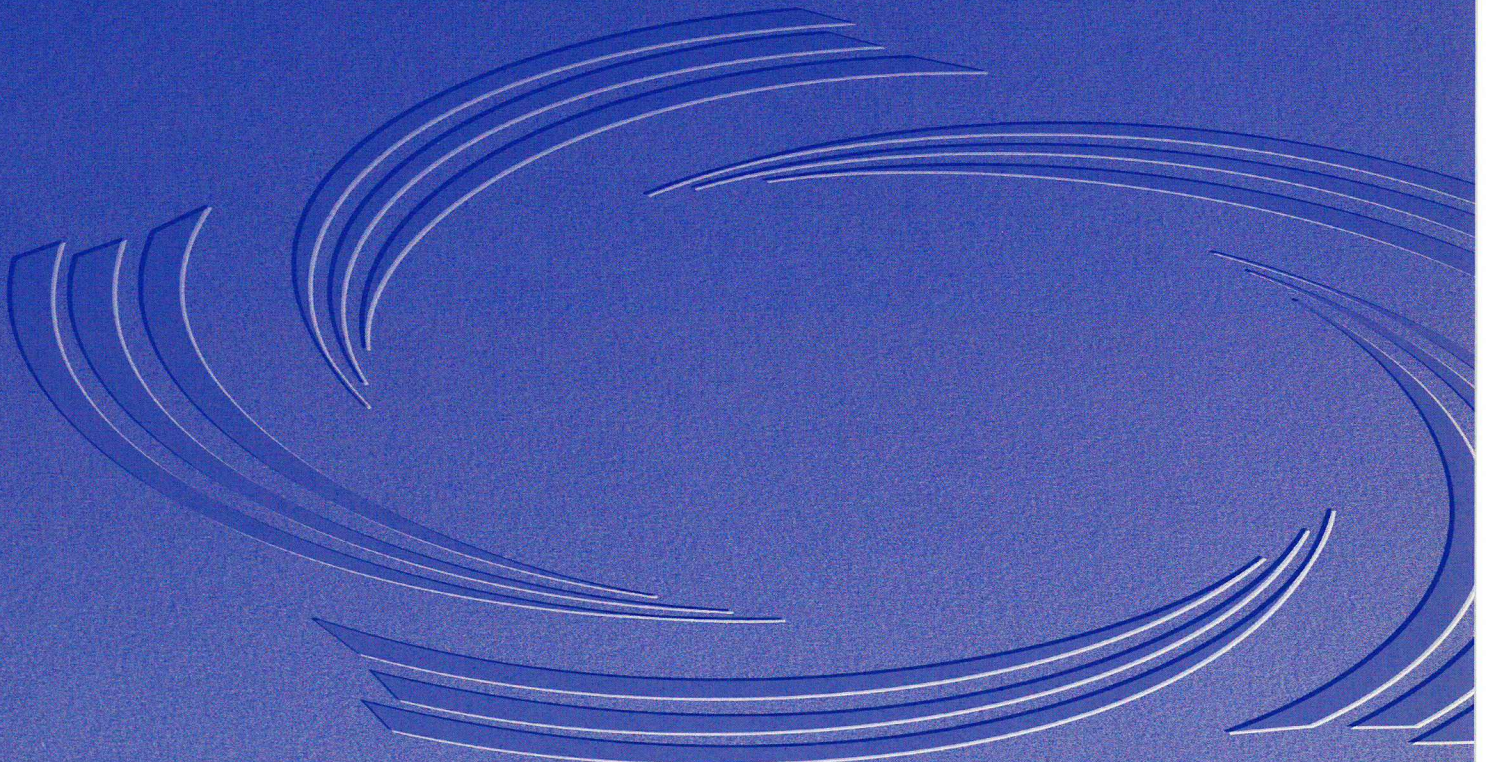



SECTION 1: TARGETED UNAUTHORIZED DISCHARGES: BACKGROUND, PROBLEM DEFINITION, MITIGATION TO-DATE, AND EVALUATED ALTERNATIVES

In accordance with the Louisville and Jefferson County Metropolitan Sewer District's (MSD's) Consent Decree entered into Federal court on August 12, 2005, MSD is submitting the attached Interim Sanitary Sewer Discharge Plan (ISSDP) to the Kentucky Department of Environmental Protection (KDEP) and the Environmental Protection Agency (EPA) for approval.

The identified areas are collectively referred to as the "targeted unauthorized discharges", as follows:

1. Beechwood Village Area
2. Hikes Point Area
3. Highgate Springs Pump Station
4. Southeast Diversion Structure

Locations for the targeted unauthorized discharges are shown in Exhibit 1. The exhibit lists the average annual number of discharges and the average annual discharge volume for each site as reported to the Division of Water for years 2002-2006. The regional wastewater treatment plants, including Morris Forman and West County, are also shown in Exhibit 1.

Section 1 of the ISSDP provides an overview of the targeted unauthorized discharges. Beginning each individual section for the targeted locations is background or historical information that will be helpful in understanding the inherent problems at the targeted location. Also outlined in the section are any previous studies, hydraulic modeling, construction projects, previous alternatives, and evaluations for a solution. A schematic showing system connectivity and unauthorized discharge relationships is shown in Figure 1.

The targeted unauthorized discharges are located within the Morris Forman Wastewater Treatment Plant (MFWTP) service area. MFWTP is the oldest and largest treatment plant in the MSD service area. With a treatment design capacity of 120 million gallons per day (MGD), the Morris Forman service area is the largest sewershed in the MSD collection system, collecting wastewater flows generated by approximately 500,000 people. There are 99 pump/lift stations in the service area and sewer pipe sizes range from 6 inch to 18 x 27 foot egg-shaped pipe.

The Southeast Diversion Structure (SED) is the juncture of two influent lines (the 30-inch Buechel Sanitary Trunk Sewer and the 33-inch Beargrass Interceptor (BGI), two effluent lines (the 30-inch Beargrass Interceptor and 60-inch Southeastern Interceptor), and, one 24-inch emergency discharge pipe which allows flow to discharge to the Beargrass Creek. As Figure 2 shows, the 33-inch Beargrass Interceptor and the 30-inch Buechel Sanitary Trunk Sewer discharge into the 30-inch BGI, creating a hydraulic restriction on the BGI. The 60-inch Southeastern Interceptor was constructed in the late 1970's to help ease this restriction. The 60-inch Southeastern Interceptor extends from the SED to the Northern Ditch Interceptor.



MSD

Louisville and Jefferson County
Metropolitan Sewer District

Interim Sanitary Sewer Discharge Plan (ISDP)

MARCH 8, 2008

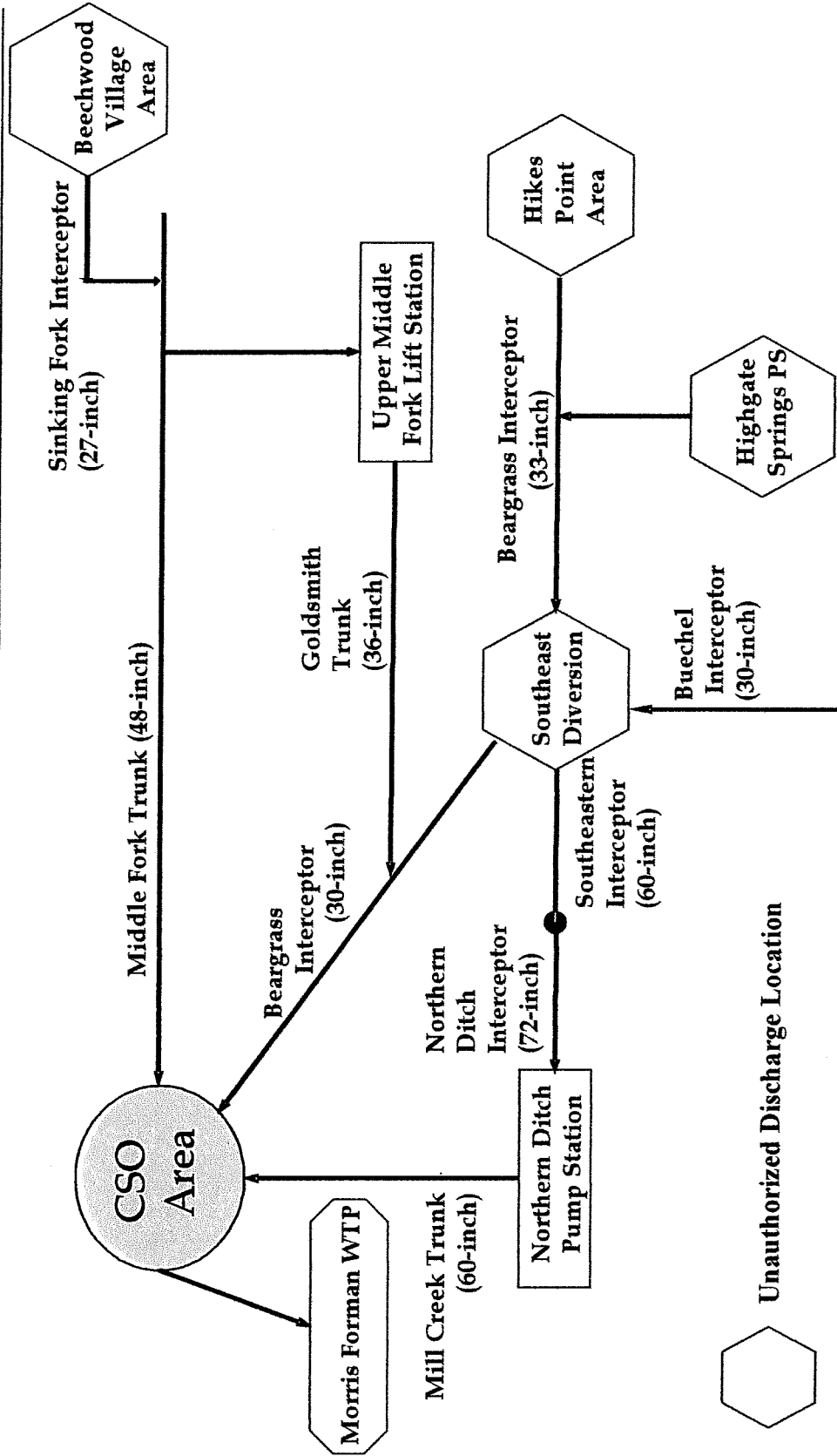

**FIGURE 1 -
UNAUTHORIZED DISCHARGE RELATIONSHIPS**

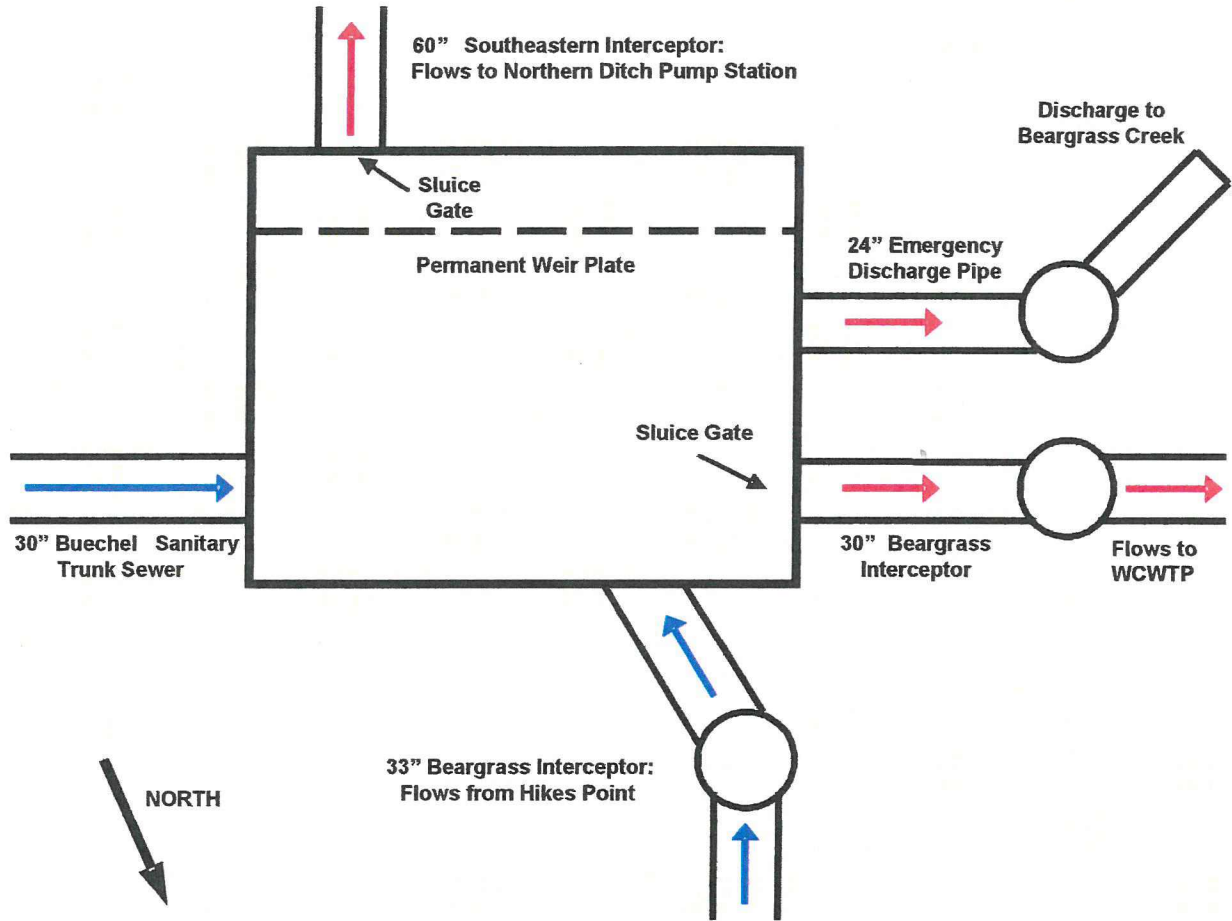

**FIGURE 2 –
SOUTHEASTERN DIVERSION STRUCTURE**



1.1 MIDDLE FORK / BEECHWOOD VILLAGE AREA

The Middle Fork study area encompasses 2,200 acres of primarily single-family residential land with small areas of industrial and commercial property. The Middle Fork area includes 65 acres of parks and 180 acres of vacant land. Servicing approximately 4,500 properties in the area are 256,000 linear feet (LF) of mainline sewer.

The City of Beechwood Village is contained within the Middle Fork area. The current population of the City of Beechwood Village is approximately 1,250 people. Constructed between September 1959 and June 1960, Beechwood Village is served by approximately 40,000 LF of 8-inch vitrified clay pipe (VCP) sanitary sewers. The system is unique, consisting mainly of parallel 8-inch sewer mains on each side of the street within the public right-of-way, resulting in relatively short property service laterals.

Problem Description in Beechwood Village

Since the construction of the neighborhood's sanitary sewers in the early 1960s, the Beechwood Village sanitary sewer system has experienced excessive infiltration/inflow (I/I). Available data suggests that the sanitary system was constructed to substandard conditions, adding to the infiltration problems typically associated with VCP. The neighborhood is also located in an area with unusually high groundwater and poor drainage. MSD acquired the system in the mid-1960s and has since been working with the neighborhood to alleviate the chronic basement backups.

There are five pumped unauthorized discharges located in or immediately adjacent to the City of Beechwood Village that are addressed by this plan. In order to reduce the risk of basement flooding in surrounding homes, excess flows from five manholes in the area are pumped into nearby drainage ditches using temporary pumps during high flow conditions. Following is a description of the five locations.

- Three pumped locations are tributary to the Sinking Fork Interceptor: Tyne Road and Cordova Road, Biltmore Road and Cordova Road, and Brunswick Road.
- One pumped location is on the Sinking Fork Interceptor immediately downstream of Beechwood Village at Shelbyville Road and Stonehenge Road.
- One pumped location is at the intersection of Shelbyville Road and Marshall Drive. At this location, the associated area does not contribute flow to the Sinking Fork Interceptor; instead, the flow passes through the Middle Fork area collectors and ultimately reaches the Middle Fork Trunk.

Table 1 shows average annual discharge frequency and volume for the Beechwood Village locations as reported to the Division of Water for years 2002-2006.



TABLE 1
BEECHWOOD VILLAGE TEMPORARY PUMP LOCATIONS,
AVERAGE ANNUAL DISCHARGE FREQUENCY AND VOLUME (2002-2006)

MSD MH ID	Location	Average Annual Discharge Frequency	Average Annual Discharge Volume, MG
21061	Tyne Rd. and Cordova Rd.	4.0 times	6.3
21089	Brunswick Rd.	3.6 times	5.0
21101	Shelbyville Rd. and Marshall Dr.	4.4 times	9.1
21153	Biltmore Rd. and Cordova Rd.	5.7 times	9.8
21156	Shelbyville Rd. and Stonehenge Rd	4.4 times	9.7
Total Average Annual Discharge Volume from Beechwood Village			39.9

1.1.1 MIDDLE FORK / BEECHWOOD VILLAGE PREVIOUS STUDIES

The Middle Fork/Beechwood Village area has been the subject of numerous studies and rehabilitation projects since MSD acquired this system in the 1960s. The following sections describe some of the studies previously undertaken to identify solutions to the sewer system problems in this area. This information is presented as background, to explain what has been tried in the past with only partial success. Additional information on these projects is contained in a variety of reports available in MSD’s archives. Since none of these projects directly relate to the ISSDP solution presented herein, only brief descriptions of these projects are provided.

During the spring of 1998 flow monitoring studies were conducted in the sub-basins of Middle Fork (Part I) and Pond Creek (Part II). The purpose of the flow monitoring study was to characterize and prioritize areas for subsequent Sanitary Sewer Evaluation Study (SSES). Once completed, the flow monitoring results were used to identify and delineate study areas for the Middle Fork SSES and West County SSES projects. The following sections contain brief historical descriptions of these and other completed studies relevant to the ISSDP.

Beechwood Village Infiltration and Inflow Investigation (1998)

This project was created to investigate the five recurring, pumped unauthorized discharges in the area. The project area included all sewer mains tributary to the unauthorized discharges, totaling 40,000 LF. Five flow monitors were installed in the spring of 1998 coincidental with the Middle Fork Flow Monitoring project. MSD crews also performed several tasks such as manhole inspections, smoke testing, dyed water flooding, and television inspections. The completed project’s data was used to characterize and prioritize the rehabilitation effort for the Beechwood Village I/I Remediation project.

Beechwood Village Post Rehabilitation Flow Monitoring (2001)

Post rehabilitation flow monitoring was conducted from February 12, 2001, through April 16, 2001, to determine the effectiveness of rehabilitation. The completed project’s results indicated



that rehabilitation projects were effective in lowering peak flow rates and excess wet weather flow volumes and averages.

Beechwood Village Abatement Study (2004)

Under this project, the Middle Fork Hydraulic model and a model of the Sinking Fork branch of the Middle Fork of Beargrass Creek were used to evaluate whether sump pump and roof leaders could be re-routed to an improved storm water collection system and discharged to the Sinking Fork.

In addition, a preliminary groundwater study in the Beechwood Village area determined that pumping down groundwater in the area does not alleviate the need for sump pumps. This completed study identified that many of the basements in Beechwood Village do require sump pumps because basements were constructed through a layer of soil that acts as a cap to an aquifer that recharges during wet weather and becomes pressurized.

1.1.2 MIDDLE FORK / BEECHWOOD VILLAGE HYDRAULIC MODELING

The Middle Fork model was originally developed as two separate models: the Middle Fork East and Middle Fork West models. The two models were eventually joined together to make the current Middle Fork Model, which includes the entire Middle Fork collection system (pipe sizes ranging from 8-inch and larger). The Middle Fork East Model encompasses the upper Middle Fork Interceptor. The Middle Fork West model encompasses the lower Middle Fork Interceptor, the Sinking Fork Interceptor, and the Middle Fork Trunk which ultimately flow to MSD's Combined Sewer System (CSS). In addition, the Middle Fork West Model includes the Beechwood Village area, which is tributary to the Sinking Fork Interceptor.

The Middle Fork models were initially calibrated in 2003 using 1998 flow monitoring and rain gauge data. The calibrated models were used to evaluate proposed solutions to the unauthorized discharges in the Middle Fork Watershed. This model was also used to evaluate whether the Upper Middle Fork Pump Station should be included in MSD's Real Time Control (RTC) system. Moreover, the models provided more accurate sanitary sewer discharge volume estimates to the Beargrass Creek Water Quality Tool for use in developing the Beargrass Creek TMDL (Total Maximum Daily Load) and evaluated unauthorized discharge abatement projects in the Woodland Hills and Hurstbourne Pump Station area.

Additional flow monitoring was performed between December 2003 and February 2004. The Middle Fork models were recalibrated to include this flow monitoring and rain gauge data.

1.1.3 MIDDLE FORK / BEECHWOOD VILLAGE PREVIOUS CONSTRUCTION WORK

This section summarizes the previous rehabilitation, I/I remediation, and private property disconnections performed in the Beechwood Village area. The Middle Fork/Beechwood Village area has been the subject of numerous rehabilitation projects since MSD acquired this system in the 1960s. The following sections describe some of the efforts previously undertaken to remedy the sewer system problems in this area. This information is presented as background, to explain what has been tried in the past with only partial success. Additional information on these projects is contained in a variety of reports available in MSD's archives. Since none of these projects directly relate to the ISSDP solution presented herein, only brief descriptions of these projects are provided.



Beechwood Village Private Property Disconnection Pilot Project (1999)

The pilot project, now completed, consisted of identifying and correcting private property sources of inflow to the separate sanitary sewer system in the Beechwood Village area. Approximately 640 homes were included in this pilot area and corrections were provided at no cost to customers who voluntarily participated. Forty-one percent of the properties were inspected; fifty-two improper connections were identified and approximately thirty were corrected with the homeowners' approval.

Beechwood Village I/I Remediation (2001)

The scope of this project was to perform I/I remediation in Beechwood Village. Completed remediation tasks included the installation of 24 chimney seals and 10,991 LF of sewer main lining.

Middle Fork Phase 2 (2001)

The scope of this project, now completed, was to complete remediation recommendations made during the Beechwood Village SSES. Specific tasks included the installation of 382 chimney seals, 1,872 LF of sewer main lining, and potential elimination of private sources of inflow as recommended in the I/I investigation.

Beechwood Village Lateral Lining (2004)

The Beechwood Village Lateral Lining project, implemented by the MSD Infrastructure and Flood Protection Division, was in effect a continuation of the Beechwood Village Rehabilitation Phase 1 which occurred between July 1, 1999 and June 30, 2000. The 2004 project rehabilitated the laterals upstream of MH21101, an emergency pumped, unauthorized discharge site located at Marshall Drive and Shelbyville Road. The previously mentioned Phase 1 project rehabilitated a portion of the area's lateral linings up to the resident's property lines only. This project continued, and extended, those rehabilitations to the residence itself. In addition, laterals not lined during the Phase 1 project were rehabilitated up to the residence as well. Upon completion of the Lateral Lining project, all of the main lines, laterals, and manhole chimneys in the Beechwood Village area were for all practical purposes rehabilitated.

1.1.4 MIDDLE FORK / BEECHWOOD VILLAGE EVALUATED ALTERNATIVES

As part of the previously discussed Abatement Study, two scenarios were evaluated for eliminating the unauthorized discharges in the Beechwood Village area.

- One scenario included the installation of a new sanitary system to replace the Beechwood Village collection system.
- Another scenario evaluated upsizing interceptors 12-inch and larger, replacing the parallel sewers along Cordova Avenue, and installing backflow valves on private connections in the area.

Although both of these alternatives individually would have significantly reduced the unauthorized discharges in the Beechwood Village area, they would only eliminate the need for four of the five emergency pumps. Therefore, a combination of both scenarios (eliminating excessive I/I and increasing interceptor sizes) would be required to eliminate basement backups and unauthorized discharges in the Beechwood Village system.



1.2 HIKES POINT AREA AND HIGHGATE SPRINGS PUMP STATION

The Hikes Point study area encompasses 4,100 acres of primarily single-family residential and commercial property. The Hikes Point area includes 83 acres of parks and 285 acres of vacant land. The area consists of 524,000 LF of mainline sewer serving approximately 8,500 properties.

The Hikes Point sewer system is divided into two sections. The first section is served by a 33-inch interceptor located upstream of the SED. The second section is the area tributary to the BGI located downstream of the SED and upstream of the combined sewer area.

Originally, the Highgate Springs Pump Station (HSPS) was designed as a temporary pumping station that would be eliminated once relief sewers were built to relieve flow in the BGI. The relief sewers were constructed but did not prevent surcharging in the Highgate Spring sewer system. Therefore, the HSPS could not be eliminated. The HSPS is a frequent and high volume unauthorized discharge location in the MSD system. The HSPS discharges an average of six times per year with a total annual discharge volume of 22.8 MG per year, as reported to the Division of Water for years 2002 -2006.

Problem Description in Hikes Point Area

The Hikes Point area covers approximately 8.6 square miles and the sewer system contains a total of 750,000 LF (142 miles) of gravity sewer pipe ranging in size from 8-inch to 48-inch. Of the entire sewershed, 55 percent of the system was installed prior to 1970, and 68 percent of the system consists of VCP.

Table 2 represents average annual discharge frequency and volume for the Hikes Point unauthorized discharge locations as reported to the Division of Water for years 2002-2006.

**TABLE 2
HIKES POINT TEMPORARY PUMP LOCATIONS,
AVERAGE ANNUAL DISCHARGE FREQUENCY AND VOLUME (2002-2006)**

MSD MH ID	Location	Average Annual Discharge Frequency	Average Annual Discharge Volume, MG
17571	Carson Way at Ribble Rd.	4.6 times	6.4
18471	Dell Brooke Ave. at Boaires Ln.	4.0 times	8.4
18483	Rio Rita Ave. at Boaires Ln.	3.0 times	5.2
18505	Flora Ave. at Ramona Ave.	2.8 times	5.6
18595	Wedgewood Way	3.0 times	5.6
Total Average Annual Discharge Volume from Hikes Point			31.1

The five pumped unauthorized discharges located in Hikes Point are part of the targeted locations addressed in this plan. Currently, these unauthorized discharges are being operated in a similar manner to those in the Beechwood Village area (i.e. pumping to reduce risk of basement flooding).



1.2.1 HIKES POINT AREA PREVIOUS STUDIES

The Hikes Point area has been the subject of numerous studies over the past decade. The following sections describe some of the studies previously undertaken to identify solutions to the sewer system problems in this area. This information is presented as background, to explain what has been tried in the past with only partial success. Additional information on these projects is contained in a variety of reports available in MSD's archives. Since none of these projects directly relate to the ISSDP solution presented herein, only brief descriptions of these projects are provided.

Hikes Point Sewer Investigation (1997)

During the March 1, 1997 storm, extensive basement flooding occurred in the general area near the Highgate Springs subdivision in the Hikes Point area. This area included the sewershed area along the South Fork of Beargrass Creek upstream of the combined sewer area. As part of this project, MSD implemented intensive sewer system investigation techniques and XP-SWMM models to assess problems and recommend solutions to reduce or prevent similar flooding in the future.

Hikes Point Post Rehabilitation Flow Monitoring (2001)

This project, now completed, was conducted to assess the effectiveness of 1999 – 2000 rehabilitation projects. Results indicated that rehabilitation projects were effective in lowering peak flow rates and wet weather flow volumes and averages.

Hikes Point Real-Time Control Flow Monitoring (2002)

The scope of this now finished project was to obtain accurate wet and dry weather flow response data for the Hikes Point collection system in order to calibrate the existing Hikes Point Hydraulic Model to RTC standards.

Hikes Point Post Rehabilitation Flow Monitoring (2002)

This project was conducted to assess the effectiveness of 2000 – 2001 rehabilitation projects. Final results indicated that rehabilitation projects were effective in lowering peak flow rates and wet weather flow volumes and averages.

Hikes Point System Improvements Phase 1 (2004)

This completed project was the initial system improvements study that set the foundation for the design of the Hikes Point solution presented in Section 2 of this report. The project used the Hikes Point XP SWMM Hydraulic Model developed between July 1, 1997 and June 30, 1998 and recalibrated between July 1, 2001 and June 30, 2002 to develop a solution to eliminate unauthorized discharges, both model-predicted and known.

These unauthorized discharges include the four temporary pump locations (not including Carson Way at Ribble Road) and the HSPS. The Phase 1 solution to eliminate pumped unauthorized discharges was the construction of a new interceptor along Hikes Lane to the SED. This new interceptor would convey flow to the SED from the BGI upstream of HSPS and the collection systems to the southeast of Hikes Lane. The existing BGI would continue to convey flow from the Highgate Springs system and Hikes Point area. Additional project details and schematic for the solution are available in Section 2 of this report.



Hikes Point Capacity Assessment (2005)

This assessment, built on the Hikes Point System Improvements Phase 1 study discussed previously, used the Hikes Point XP SWMM Hydraulic Model developed between July 1, 1997 and June 30, 1998 and recalibrated between July 1, 2001 and June 30, 2002. The objective was to refine solutions developed in the Phase 1 study and evaluate the feasibility of redirecting flow external to the Hikes Point system through this area. This option would route flows from the Middle Fork of Beargrass Creek collection system through Hikes Point to the West County Wastewater Treatment Plant (WCWTP). In addition, cost estimates were refined and field verification was performed to help identify the most viable abatement options.

1.2.2 HIKES POINT AREA HYDRAULIC MODELING

The Hikes Point XP-SWMM hydraulic model was originally developed as part of the 1998 SSES. It was updated and recalibrated in 2002 for use with the RTC system developed by MSD. This model includes the collection system (8-inch pipes and larger) that is tributary to the Hikes Point branch of the BGI. The model also includes the HSPS and four of the five pumped unauthorized discharges. The "pumped unauthorized discharge" located at Carson Way and Ribble Road was not modeled. This pumped unauthorized discharge location is hydraulically separate because it is located in the Hawthorne neighborhood of Hikes Point, and is tributary to the Goldsmith Lane Trunk.

1.2.3 HIKES POINT AREA PREVIOUS CONSTRUCTION WORK

This section summarizes the previous rehabilitation and private property disconnections performed in the Hikes Point area. The Hikes Point area has been the subject of numerous rehabilitation projects over the past decade. The following sections describe some of the efforts previously undertaken to remedy the sewer system problems in this area. This information is presented as background, to explain what has been tried in the past with only partial success. Additional information on these projects is contained in a variety of reports available in MSD's archives. Since none of these projects directly relate to the ISSDP solution presented herein, only brief descriptions of these projects are provided.

Hikes Point Private Property Disconnection Pilot Project (1999)

This project consisted of identifying and correcting private property sources of inflow to the separate sanitary sewer system in the Carson Way, Ribble Road area of Hikes Point. Corrections were provided at no cost to customers who voluntarily participated in the Hikes Point Neighborhood. Approximately 300 homes were included in this pilot area. Approximately 20 percent of the residents participated in the program by disconnecting their sump pumps and downspouts from the sanitary sewer system.

Hikes Point Infiltration and Inflow Remediation Phase 1A (1999)

This project consisted of performing 7,611 LF of cured-in-place pipe (CIPP) lining to address indirect storm water cross connections and the installation of 309 mechanical chimney seals in



basins with the highest wet weather peaking factors. Rehabilitation was based on the most severe defects identified by the previous Hikes Point SSES.

Hikes Point Infiltration and Inflow Remediation Phase 1B (2000)

The project replaced 15-inch and 16-inch sewer lines along Rio Rita Avenue and Boaires Lane with a 21-inch sewer line. The 21-inch line increased available wet weather capacity and helped to reduce unauthorized discharges and basement flooding in the area.

Hikes Point Infiltration and Inflow Remediation Phase 3 (2000)

This project consisted of performing 8,062 LF of CIPP lining and rehabilitating 95 laterals in the Highgate Springs area. Rehabilitation projects were performed for the most severe defects identified by the previous Hikes Point SSES and additional television inspection.

Hikes Point Infiltration and Inflow Remediation Phase 2 (2001)

This project consisted of installing 701 mechanical chimney seals throughout the Hikes Point area. Rehabilitation projects were performed for the most severe defects identified by the previous Hikes Point SSES.

1.2.4 HIKES POINT EVALUATED ALTERNATIVES

Based on the findings from the Hikes Point System Improvements project, several alternatives have been previously evaluated to eliminate the Hikes Point unauthorized discharges. The alternatives were tested using the Hikes Point XP-SWMM hydraulic model.

A summary of the alternatives analyzed are presented herein and shown in Figure 3:

- **Conveyance (Gravity Option):** This option was to provide additional capacity within the Hikes Point system for handling the pumped unauthorized discharges and ensure that the system had adequate capacity for conveying the flow to the Hikes Point branch of the BGI. A relief sewer was needed to free capacity in the BGI in order to convey flow from the Hikes Point area and to eliminate the HSPS unauthorized discharge. In addition, the relief sewer needed adequate capacity to convey BGI flow upstream of the intersection of Hikes Lane and Beargrass Creek, as well as enough capacity to convey a portion of the flow from the HSPS. This solution was ultimately identified as the only solution that was adequate for conveying flow to the SED without extensive, long term maintenance requirements, and with limited disruption to customers.
- **Conveyance (Force Main):** This alternative was to construct a new force main between the HSPS and the SED. The force main would also convey wet weather flow from the HSPS service area, specifically to eliminate the unauthorized discharge at the pump station, as well as to relieve capacity problems in the BGI. This option was ultimately eliminated because the removal of HSPS flow alone was insufficient to eliminate unauthorized discharges in the Hikes Point area.
- **High-Rate Treatment or Storage:** This option was to convey flow from the Hikes Point system to the SED and construct either a high-rate treatment facility, or a storage basin at the SED. This would contain the unauthorized discharge volumes from the Hikes Point system and the SED. This option was only acceptable as an interim



solution since it would require either a remote wet weather treatment facility, or an unacceptably large storage facility.

- **Flow reduction:** This alternative was to replace service laterals to homes with basements in the Hikes Point area. This would potentially reduce flow in the BGI and reduce the unauthorized discharge volume at the SED. This option was considered due to a common construction practice of installing perforated pipe to create positive drainage around foundations in the Hikes Point area. In this alternative, the pipe was frequently connected directly to the lateral serving the home. This condition, in conjunction with high groundwater levels, could account for a significant portion of high base infiltration rates identified during flow monitoring. This solution was ultimately discarded as a stand alone alternative due to extremely high costs and disruption to the community.

As previously stated, the Conveyance (Gravity) alternative was found to eliminate all pumped unauthorized discharges by routing BGI flow upstream of HSPS through a new interceptor along Hikes Lane to the SED. In addition, the SED would have no long-term maintenance requirements and have limited disruption to customers. The new Hikes Lane Interceptor would convey approximately 80 percent of flow upstream of HSPS and the collection systems to the southeast of Hikes Lane to the SED. The existing BGI downstream of the Highgate Springs effluent line would convey the remainder of flow from the Highgate Springs system and the Hikes Point area.

This option would serve as relief to the existing BGI capacity problems. Refer to Figure 4 for a schematic of how flow will be conveyed through Hikes Point as a result of the new Hikes Lane Interceptor.

The advantage to the new interceptor constructed along Hikes Lane is that it would allow the elimination of the HSPS. Nearly two-thirds of the existing system would need to be re-directed to the new interceptor and the remaining one-third could flow directly to the BGI through the existing system.

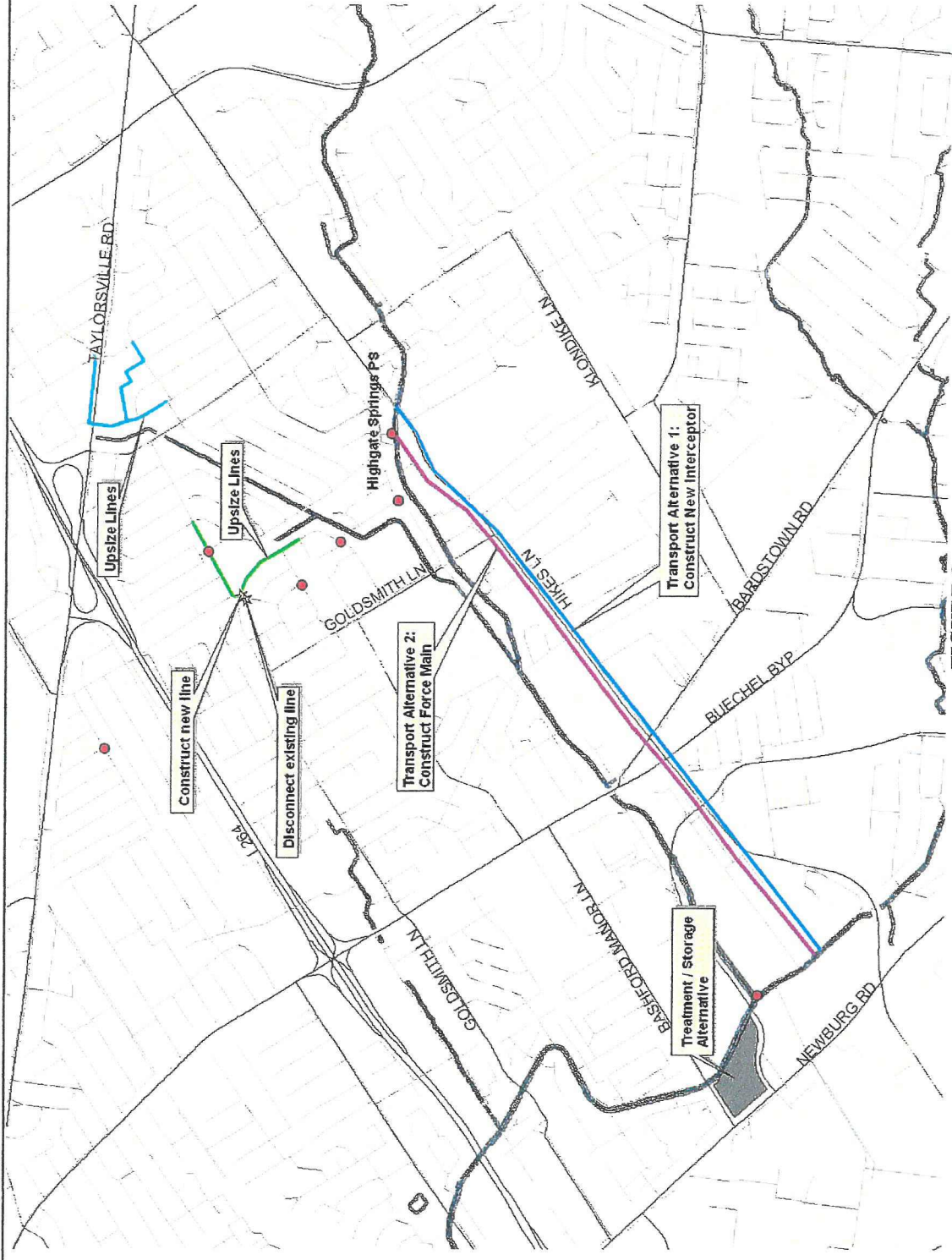
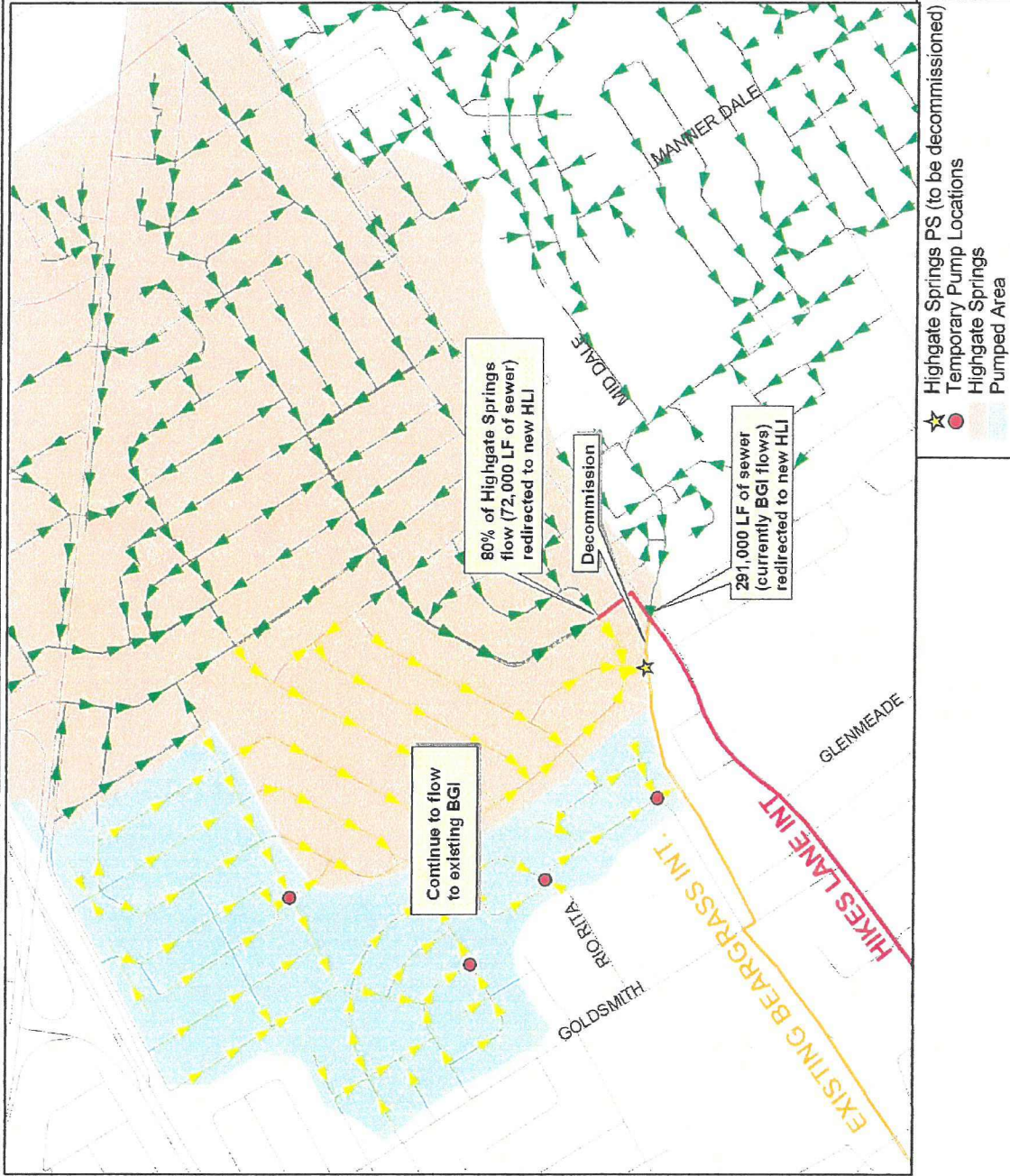

FIGURE 3 -
HIKES POINT SYSTEM IMPROVEMENTS ALTERNATIVES



MSD

Louisville and Jefferson County
Metropolitan Sewer District



**FIGURE 4 –
CONVEYANCE OF FLOWS THROUGH HIKES POINT**

1.3 SOUTHEAST DIVERSION STRUCTURE / POND CREEK AREA

The Pond Creek area covers approximately 36 square miles and is centrally located at the intersection of Preston Highway and I-265. The sewer system contains a total of 2,220,000 linear feet (420 miles) of gravity sewer pipe ranging in size from 8-inch to 10-foot. The majority of the land use in the service area is residential and undeveloped/vacant land.

Problem Description in Southeast Diversion Structure and Pond Creek area

Historically, the SED has been a frequent and high volume unauthorized discharge location in MSD's service area. The recent addition of gate controls, installed as part of the RTC project, has reduced both the frequency and volume of discharges.

1.3.1 POND CREEK PREVIOUS STUDIES

The Pond Creek Village area has been the subject of numerous studies over the past decade. The following sections describe some of the efforts previously undertaken to identify solutions to the I/I problems in this area. This information is presented as background, to explain what has been tried in the past with only partial success. Additional information on these projects is contained in a variety of reports available in MSD's archives. Since none of these projects directly relate to the ISSDP solution presented herein, only brief descriptions of these projects are provided.

Priority Flow Monitoring Part 2: Pond Creek (1998)

This study was developed to characterize and help prioritize the 48 sub-basins in Pond Creek for further study and rehabilitation through the analysis of wet and dry-weather flow data, customer's sewer backup complaints, and MSD's unauthorized discharge reports. Monitors were maintained and data collected from April 13, 1998 through May 27, 1998.

Pond Creek Sanitary Sewer Evaluation Studies (2004)

The objective of this study was to identify sources of excessive I/I and structural defects in the sanitary system. This information would be used to plan rehabilitation projects to reduce excessive I/I and the associated frequency and volume of unauthorized discharges.

The study included reviews of existing data (Louisville and Jefferson County Information Consortium (LOJIC), Hansen Information Management System, & flow data); 1,200 manhole inspections; smoke testing (193,000 LF sewer); TV inspections (16,650 LF sewer), and Focused Electrode Leak Locator (FELL-41) inspections (23,500 LF of sewer). In addition, the study conducted flow isolations to quantify and locate constant sources of infiltration. Analyzing data generated during the SSES helped to identify the defects that allow excessive I/I to enter the system, determine corrective actions to address defects, and prioritize sub-basins for rehabilitation.

The study showed the system was in relatively sound structural condition compared to other systems of similar age. Constant infiltration was the dominant problem; however, it may have been masking a rain derived inflow problem. Few major defects were found. The majority of public side inflow was attributed to manholes (leaking riser rings and offset frames). The majority



of public side infiltration was attributed to cracked pipes and leaking joints due to root intrusions. Private side contribution sources were rare as only defective cleanouts were identified.

However, as the area was suspected to suffer from a high water table, there may be sump pumps that contributed to the high base flows even during dry weather conditions. Locations of maintenance-related issues such as root intrusions and grease build-up were provided to the MSD Infrastructure and Flood Protection Division for action. The project was completed in October 2004.

1.3.2 POND CREEK HYDRAULIC MODELING

The Pond Creek hydraulic model was calibrated between July 1, 2001 and June 30, 2002 using flow monitoring data collected between July 1, 1997 and June 30, 1998. The model consisted of 10-inch and greater sanitary sewers tributary to the Pond Creek and Mill Creek interceptors but did not include the Valley Village Interceptor (these models were joined and the Valley Village interceptor was added under the WCWTP Spline model built under the West County Conveyance System Improvements Project). This model was completed in January 2003 and re-calibrated using flow monitoring data collected between July 10, 2003 and June 30, 2003.

Northern Ditch (2002)

The Northern Ditch XP-SWMM model of the Pond Creek area was built to assist with development of the RTC system currently used by MSD to reduce overflow volumes in the combined sewer system. The model was originally built and calibrated in 2002 using 2002 flow monitoring data. The West County Spline model was recalibrated to 2005 flow data as part of the Pond Creek Capacity Improvement Alternatives project to evaluate the effectiveness of various storage/conveyance solutions.

1.3.3 SOUTHEAST DIVERSION / POND CREEK PREVIOUS CAPACITY ASSESSMENTS AND EVALUATED ALTERNATIVES

Pond Creek Capacity Alternatives

The Pond Creek and Mill Creek conveyance systems experienced very high wet weather flows in 2002, leading to emergency repairs to identifiable system deficiencies. These repairs were completed in early 2003 and have significantly reduced wet weather peaks. In 2003, a conceptual design report studied the "post improvements" condition and concluded that a combination of in-line storage in the existing interceptors plus a wet weather storage basin, located in the northeast corner of the WCWTP site, could eliminate additional unauthorized discharges. A conceptual plan and preliminary design report were prepared for this basin. This project involved modeling of the WCWTP system to evaluate the costs and effectiveness of in-line and in-basin storage against high-rate treatment systems. An array of hydraulic models was constructed to determine the configuration of in-line controls that would provide maximum reduction of unauthorized discharges.

The Pond Creek Capacity Improvement Alternatives Phase I Project

The Pond Creek Capacity Improvement Alternatives Phase I project was initiated before the ISSDP solution had been developed, and, therefore, focused on identifying storage and treatment options in order to ensure flows into the WCWTP were being treated. In addition, an analysis was



performed that evaluated both in-line and off-line storage as a means to cost-effectively capture the peak flows. The analysis showed that the total capital cost (treatment and storage) decreases with increasing storage volume. The study evaluated in-line storage using fixed weirs or inflatable dams, which have the potential to provide inexpensive capacity to store wet weather flows.

The West County Spline model developed in 2002 was verified against 2005 flow data and was used to evaluate the effectiveness of various storage/conveyance solutions. In this application, inflatable dams were found to be marginally effective at storing flow within the Pond Creek Interceptor due to the timing issues involved in managing the storm surge. Fixed flow-through weirs were recommended as they were found to provide significant in-line storage, decreased unauthorized discharges, and were economical to construct within the Pond Creek Interceptor.

The Hikes Point Capacity Analysis project examined the capacities of the Southeastern and Northern Ditch Interceptors. It was determined that the Interceptors do not have sufficient capacities to convey flows developed at the SED to the Northern Ditch Pump Station and ultimately to treatment. An existing 72-inch stub had been identified on the Pond Creek Interceptor during the Pond Creek Storage Alternatives Project Phase 1 and a decision was made to explore the impacts of connecting the Northern Ditch Interceptor to the Pond Creek Interceptor at the 72-inch stub via a new interceptor identified as the Northern Ditch Diversion Interceptor (NDDI).

Model runs were made to determine the maximum flow that could pass through the proposed NDDI and the Northern Ditch Pump Station. This established the maximum flow that could be transported from the SED. It was determined that the Northern Ditch Interceptor required a 84-inch relief sewer so that these flows could be conveyed to the proposed NDDI. The remaining excess volume at the SED was used to determine the storage requirements for an off-line storage facility along the Southeastern Interceptor.

The Pond Creek Capacity Improvement Alternatives Phase 2 Project

An evaluation of the impacts on the West County Wastewater Treatment Plant was then conducted using the Pond Creek Hydraulic Model under the Pond Creek Capacity Alternatives Phase 2 project. The Phase 2 project analysis began with the flow-through weirs identified in Phase 1 located upstream and downstream of the NDDI / Pond Creek Interceptor junction.

The results of this evaluation indicate that peak system performance is achieved without in-line storage; however, modifications to the WCWTP, in the form of on-site storage and high-rate treatment, would be necessary.

Additional modeling was performed as part of the ISSDP to evaluate the viability of conveying wet weather flows to the BGI. These models determined that the storage along the Southeastern Interceptor could be eliminated. This would result in redirecting flow away from the CSO system except under peak wet weather conditions.

1.3.4 SOUTHEAST DIVERSION / POND CREEK BOUNDARY CONDITIONS

As mentioned previously, the development of the proposed ISSDP solution occurred during the final stages of the Pond Creek Capacity Alternatives Phase 1 project. Given the need to provide treatment for additional flows resulting from unauthorized discharge elimination under the ISSDP solution, a decision was made to expand the scope of the Phase 1 study to explore the impacts of increasing the capacity of the Southeastern Interceptor and connecting the

Northern Ditch Interceptor to the Pond Creek Interceptor via a new interceptor previously identified as the NDDI. The new relief sewer is proposed as an 84-inch interceptor to accommodate a portion of the full flow conditions from the new 72-inch Hikes Lane Interceptor.

1.4 WEST COUNTY WASTEWATER TREATMENT PLANT BACKGROUND

The West County service area serves approximately 51,000 customers and contains approximately 4,000,000 linear feet of pipe. The service area includes 60 pump/lift stations and consists primarily of 8-inch VCP and PVC pipe.

The construction of the WCWTP began in 1984 and the plant went into service in 1986 with a design capacity of 15 million gallons per day. The WCWTP enabled the elimination of more than 45 small treatment plants, numerous pump stations, and septic systems in the Pond Creek and Mill Creek areas. As the service area and population has grown, capacity has been added. The current design capacity of the plant is 30 million gallons per day and the average flow rate is 21.8 million gallons per day.

1.4.1 WEST COUNTY WASTEWATER TREATMENT PLANT HYDRAULIC MODELING

West County Flow Monitoring (2003)

Between July 1, 2002 and June 30, 2003, thirteen flow monitors and two rain gauges were installed and maintained from December 23, 2002 through February 5, 2003. The purpose of this project was to collect average dry weather flow and wet weather response data to be used for the recalibration of the WCWTP Spline Model to reflect post rehabilitation flow rates.

WCWTP Spline (2003)

This model was built by joining the Mill Creek model with a spline model of the Pond Creek system. Originally, this model was calibrated between July 1, 2001 and June 30, 2002 using earlier flow monitoring data in the Pond Creek (July 1, 1997 – June 30, 1998) and Mill Creek (July 1, 2001 – June 30, 2002) systems. This model was re-calibrated using post rehabilitation flow monitoring data collected between July 1, 2002 and June 30, 2003 to reflect system changes due to interceptor repairs under the West County Conveyance System Improvements Project. This model was used for analysis of the proposed Pond Creek Interceptor Storage Basin and to identify system corrections to eliminate the direct entry of floodwaters from Mill Creek to the system.

In addition, this model was used to evaluate inline storage options as part of the Pond Creek Capacity Alternatives project initiated in late 2005.

1.4.2 WEST COUNTY WASTEWATER TREATMENT PLANT PREVIOUS CAPACITY ASSESSMENTS AND EVALUATED ALTERNATIVES

The Pond Creek Capacity Improvement Alternatives Phase I project performed wet weather simulations used to identify peak wastewater flows received at the WCWTP and collection system at various WCWTP capacity expansions. Expanded capacities of 50, 80, 100, 140, and 180 MGD were simulated for various recurrence storms. This analysis incorporated a flow equalization basin located on the WCWTP property to capture excess wastewater. Analysis



MSD

Louisville and Jefferson County
Metropolitan Sewer District

Interim Sanitary Sewer Discharge Plan (ISSDP)

MARCH 8, 2008

yielded calculations of collection system unauthorized discharges and basin volume utilization for each WCWTP capacity at the various recurrence intervals. However, restrictions in the collection system become a controlling factor at expanded capacities at or greater than 100 MGD. Therefore, preliminarily, a 100 MGD wet weather treatment facility was recommended in order to capture the maximum flow that can be delivered to the plant under these flow conditions.



MSD

Louisville and Jefferson County
Metropolitan Sewer District



SECTION 2: THE INTERIM SANITARY SEWER DISCHARGE PLAN SOLUTION

Section 1 provides the background for how the recommended solutions were developed as a viable solution. In Section 2, the recommended ISSDP solution is outlined in detail.

Although past rehabilitation projects have played a significant role in reducing the frequencies and volumes of the targeted unauthorized discharges, these efforts alone have not been successful in fully eliminating them. Therefore, MSD has developed an integrated design concept to eliminate the targeted unauthorized discharges outlined in the Consent Decree. The targeted solution incorporates findings from previous studies, sewer rehabilitation projects, sewer system capacity assessment, sewer system flow monitoring, and computer modeling efforts throughout Jefferson County into a holistic design. The ISSDP solution is illustrated in Exhibit 2.

2.1 MIDDLE FORK / BEECHWOOD VILLAGE RECOMMENDED SOLUTION

The plan for eliminating unauthorized discharges in the Middle Fork/Beechwood Village area includes replacing the local collection system in Beechwood Village thereby reducing the I/I into the Sinking Fork Interceptor, as shown in Exhibit 3. More specifically, it consists of replacing the sanitary sewer system up to, and including, the homeowner's service connection in approximately 580 homes within the Beechwood Village neighborhood. This plan would happen in two phases (East and West) as shown in Figure 5. In this phased improvement plan, the existing sanitary sewer lines may remain in place, be disconnected from the Sinking Fork Interceptor, and serve as stormwater collection pipes collecting existing connected sump pumps, floor drains, and roof drains. Residential property sanitary service connections will be reconfigured to exit the property above the basement floor.

In addition, the hydraulic constriction on the Sinking Fork Interceptor at the Shelbyville Road Crossing will be removed. The recommendation includes constructing approximately 2000 LF of new 15-inch sewer near the Sinking Fork Interceptor / Shelbyville Rd. crossing and reintroducing the flow at the Sinking Fork Interceptor downstream of the constriction. The new sewer would divert a portion of the Beechwood Village neighborhood (approximately 315 homes) to relieve the constriction at the Sinking Fork Interceptor.

2.2 HIKES POINT / HIGHGATE SPRINGS PUMP STATION RECOMMENDED SOLUTION

The proposed solution for the HSPS will divert the majority of flow from Highgate Springs into a new Hikes Lane Interceptor, as shown in Exhibit 4. This new 72-inch interceptor is sized with sufficient capacity to convey all of the intercepted flow from the collection systems to the southeast of Hikes Lane and the flow from the Beargrass Creek Interceptor, as schematically illustrated in Figure 6. Once the Hikes Lane Interceptor is constructed, the HSPS will be decommissioned.



MSD

Louisville and Jefferson County
Metropolitan Sewer District

**Interim Sanitary Sewer Discharge Plan (IS-SP)
MARCH 8, 2008**



**FIGURE 5 --
BEECHWOOD VILLAGE SYSTEM IMPROVEMENTS PHASING PLAN**

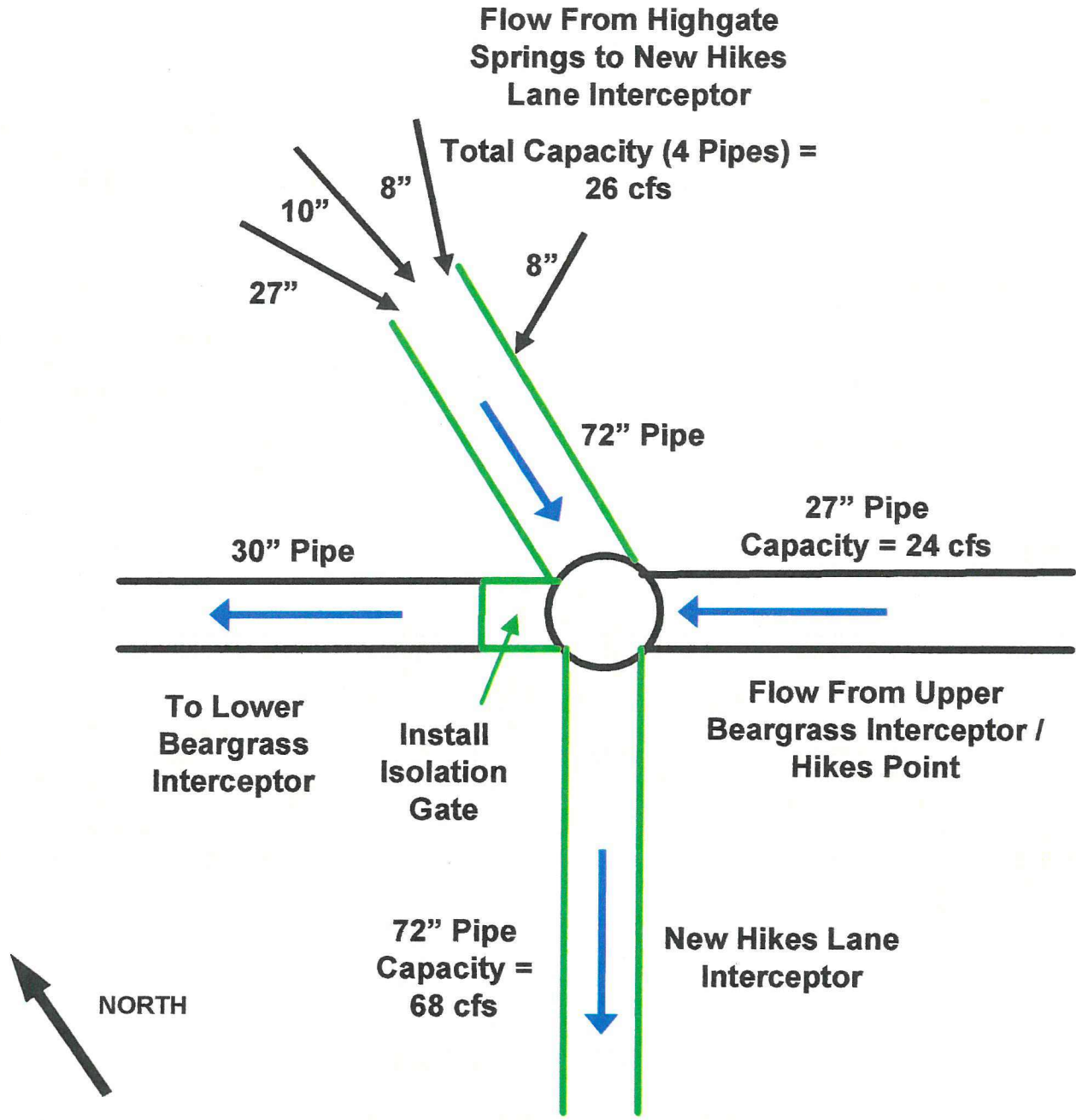

**FIGURE 6 –
PROPOSED HIKES LANE INTERCEPTOR**

The Hikes Lane Interceptor will divert sufficient flow to allow the pumped unauthorized discharge areas to continue to flow to the SED through the existing downstream portion of the Beargrass Interceptor without any modifications. Surcharging of the Beargrass Interceptor is the primary cause for the pumped unauthorized discharge at Boaires Lane and Dell Brooke. In order to mitigate the pumped unauthorized discharges in the upstream reaches of Hikes Point, 2,500 LF of the existing sewers will need to be replaced with larger diameter sewers and the hydraulic constrictions will need to be removed, as shown in Exhibit 5.

The Carson Way and Ribble Road pumped unauthorized discharge is located in the Hawthorne neighborhood of Hikes Point. Unlike the other pumped locations in the Hikes Point system which are upstream of the Hikes Point Branch of the BGI, this system flows into the Goldsmith Trunk. There are no models of this small area and traditional techniques have been used to evaluate this unauthorized discharge location. Based on the study being conducted as part of the ISSDP development, a conveyance solution is the only identified viable option. Past studies and current fieldwork indicate that the unauthorized discharge occurs at a restriction in the system. The recommended solution includes a new relief sewer from the unauthorized discharge to a new connection on the Goldsmith Trunk. Please refer to Figure 7 which illustrates the two alternatives currently being evaluated for the proposed Carson Way and Ribble Rd improvements.

2.3 SOUTHEAST DIVERSION RECOMMENDED SOLUTION

The solution for eliminating the unauthorized discharge at the SED will require constructing a new 36-inch interceptor parallel to the Southeastern Interceptor, as shown in Exhibit 6. The 36-inch interceptor is sized to ensure that the combined capacities of the sewers downstream of SED exceed the influent capacities of the sewers upstream of the SED, thus eliminating the unauthorized discharge at the SED. Refer to Figure 8 for a schematic of proposed modifications to the SED. This will also involve constructing junction structures at each end and removing the existing control weir in the SED.

The Southeastern Interceptor Relief sewer (SEI Relief) will be 3,100 LF of 36-inch sanitary sewer running between the SED and the 72-inch Northern Ditch Interceptor. During the design phase of this project, it may be decided to increase the size and capacity of this interceptor if the final Sanitary Sewer Discharge Plan recommends additional flow to be routed to the WCWTP via this interceptor

A new junction structure will be located near Fountain Drive (approximately MH 30862) that will connect the SEI Relief to the proposed Hikes Lane Interceptor and Buechel Branch Interceptor. Another structure will be required at the junction with the Northern Ditch Interceptor with control gates to prevent overwhelming the downstream system and to utilize the Southeastern Interceptor and SEI Relief for in-line storage.

Once the SEI Relief and junction structures are complete, the control weir in the SED will be removed to allow the flow from the upper Beargrass Interceptor into the Southeastern Interceptor under dry conditions. The RTC system will need to be reprogrammed to prevent flow into the Beargrass Interceptor /CSS system except under extreme wet weather conditions or to allow cleaning or inspection of the Southeastern Interceptor.



MSD

Louisville and Jefferson County
Metropolitan Sewer District

Interim Sanitary Sewer Discharge Plan (ISDP)

MARCH 8, 2008

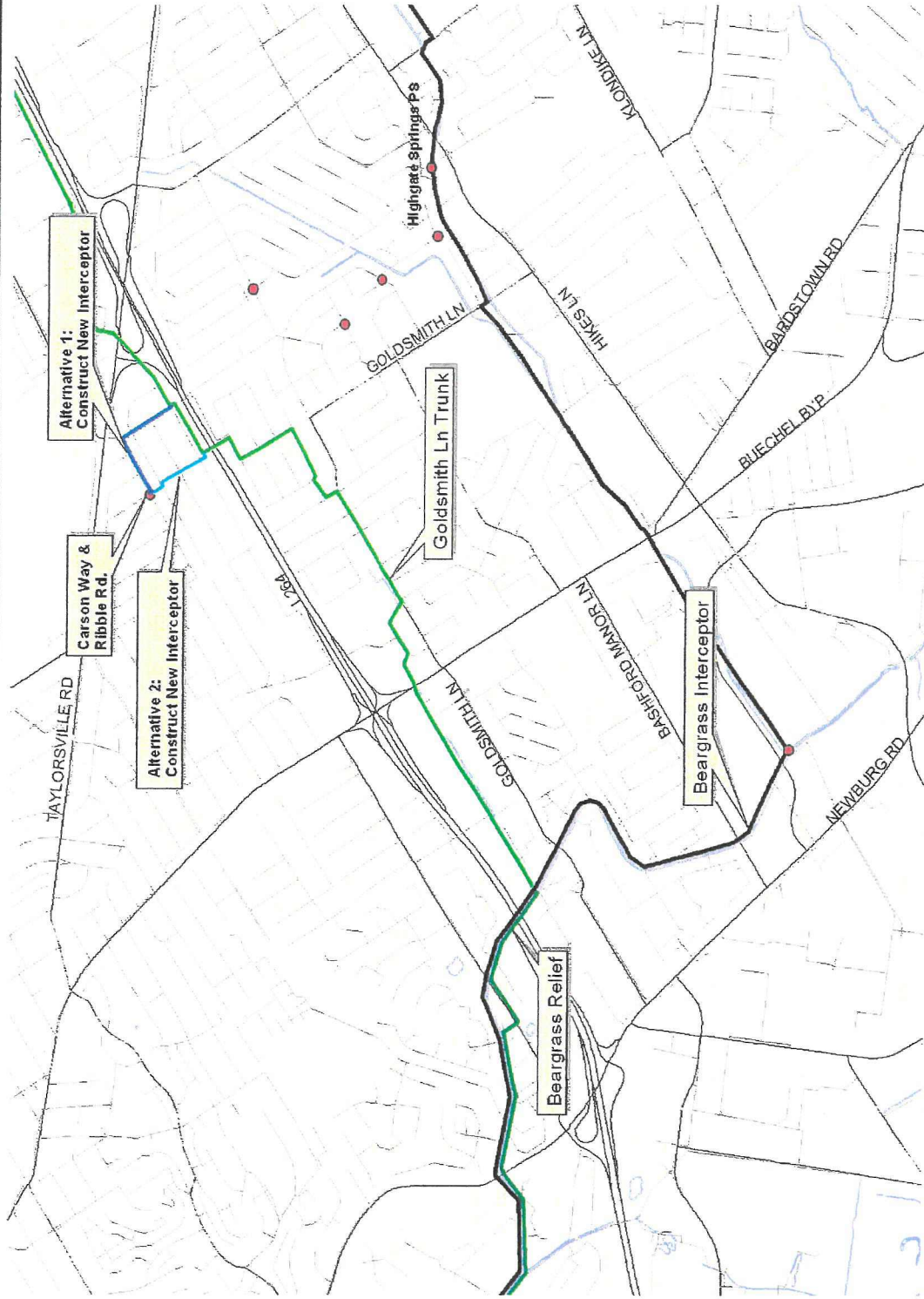

**Figure 7-
Carson Way and Ribble Rd Proposed Improvement Alternatives**

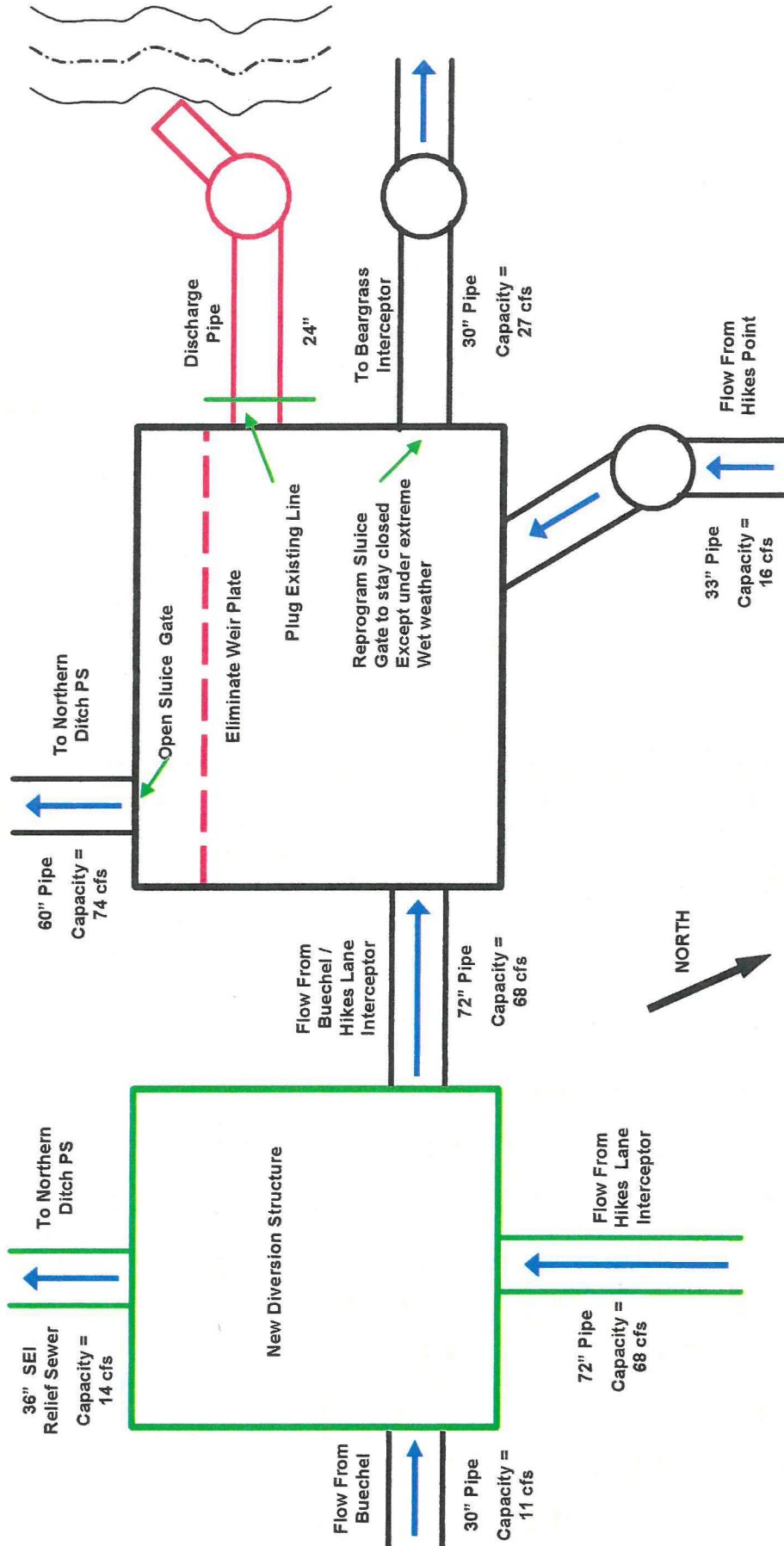

FIGURE 8 -
PROPOSED SOUTHEAST DIVERSION MODIFICATION

2.4 NORTHERN DITCH RECOMMENDED SOLUTION

A new 84-inch NDDI will divert excess flows from the Northern Ditch Pump Station to the Pond Creek Interceptor and will run 13,000 LF along Greasy Ditch from manhole 23274 on the Northern Ditch Interceptor to the existing sewer at manhole 27520 near the Pond Creek Interceptor. Exhibit 7 shows the new sewer construction that will divert the excess flows from the Northern Ditch Pump Station to the Pond Creek Interceptor.

2.5 WCWTP RECOMMENDED SOLUTION

An integral part of the WCWTP recommended solution is to continue to maximize the existing secondary treatment capacity. In order to accomplish this objective, MSD has developed wet weather protocols to guide the WCWTP operators to maximize flows through the existing process units. These protocols will be modified once the WCWTP recommended solution is constructed to ensure that flow through the secondary treatment facilities is maximized before sidestream processes are brought on-line. The proposed modifications at the WCWTP include a new flow equalization facility and additional secondary treatment facilities, as shown in Exhibit 8. Equalization facilities are to be included in the WCWTP to reduce the size and costs of the additional secondary treatment facilities.

The equalization basin would be located in the northeast corner of the WCWTP and is currently planned to be an open top, earthen basin. Although the flow entering the basin will be screened and de-gritted, it is expected that the basin will need to be cleaned after each use. Cleaning could be accomplished with water cannons and/or flushing channels. Additionally, a channel along the bottom of the basin will be constructed of concrete to allow maintenance and cleaning equipment to access the basin bottom without damaging the liner. Furthermore, the 120-inch gate at the WCWTP Screenings Building will be utilized to allow for in-line storage of wet weather flow in the Pond Creek Interceptor, which will provide benefits in managing wet weather flows to the WCWTP.

The proposed wet weather treatment facilities will utilize a combination of biological and physical/chemical processes to produce effluent that meets secondary discharge standards when operating on relatively dilute wet weather flows. The process may be an expansion of existing secondary treatment facilities (contact stabilization activated sludge) or a sidestream process designed to achieve all secondary treatment standards during the periods that it operates. If a sidestream process is selected, it would operate in parallel to the existing WCWTP facilities and the plant effluents would be recombined prior to disinfection and discharge to the Ohio River. The sidestream flows would, however, fully meet the definition of secondary treatment prior to it being recombined. The overall treatment objective is to meet the requirements of the Kentucky Pollutant Discharge Elimination System (KPDES) discharge permit for the WCWTP. As mentioned in Section 1, the proposed additional peak flow treatment capacity is 100 MGD, is subject to further verification during preliminary engineering. Total treatment capacity of the WCWTP will therefore be 196 mgd.

Three alternatives have been identified to provide secondary treatment of the additional wet weather flows at WCWTP. The alternatives presented herein are preliminary concepts that are currently being evaluated in greater detail in the preliminary engineering report for this facility.



Two of the alternatives are biologically active high-rate proprietary treatment systems and the third alternative is an expansion of the existing contact stabilization activated sludge conventional secondary treatment. The preliminary design criteria for the three alternatives are summarized in Table 3.

**TABLE 3
PRELIMINARY DESIGN CRITERIA FOR PROPOSED
SECONDARY TREATMENT FACILITIES AT WCWTP**

Item	High-Rate Side-Stream Treatment (Alt 1 and 2)	Conventional Contact Stabilization Treatment (Alt. 3)
Treatment Capacity	100 MGD	196 MGD
Equalization Basin Volume	36 MG	36 MG
Assumed Influent Concentration		
BOD ₅	90 mg/L	90 mg/L
TSS	160 mg/L	160 mg/L
NH ₃	20 mg/L	20 mg/L
Max Effluent Concentration (Min Percent Removal)		
BOD ₅	30 mg/L (85% Removal) *	30 mg/L (85% Removal) *
TSS	30 mg/L (85% Removal) *	30 mg/L (85% Removal) *
NH ₃	20 mg/L	20 mg/L

* Must meet 85% removal on a calculated monthly average.

Assumed influent concentrations were based on an evaluation of influent characteristics during significant wet weather events. A significant wet weather event is characterized by precipitation that caused an increase in the WCWTP influent flow above 60 mgd. Based on historical plant data, the influent total suspended solids (TSS) concentrations were generally below 160 mg/L during significant wet weather events. To achieve an effluent TSS of 30 mg/L or less under these conditions, a TSS removal of greater than 81 percent is required. Similarly, the influent 5-day biochemical oxygen demand (BOD₅) concentrations were generally below 90 mg/L during significant wet weather events. To achieve an effluent BOD₅ of 30 mg/L under wet weather conditions, the wet weather treatment plant must remove a minimum of 66 percent of the total BOD₅. At higher wet weather flows the influent concentrations could be even lower than 160 and 90 mg/l. Based on this evaluation, the percent removal requirement for BOD₅ and TSS are more stringent than the average concentrations, and percent removal will be the controlling factor for evaluating sidestream process performance. Removals will be evaluated over a range of influent



concentrations and a range of flowrates that simulate typical operation during a wet weather event. The percent removal performance will be calculated based on a monthly average of the days per month that the sidestream facilities operate.

The proposed effluent limit for ammonia-N is 20 mg/L. The WCWTP is not designed to nitrify under peak loading conditions, so ammonia-N is essentially a pass-through except for the small amounts used in the synthesis of biomass. Similarly, the wet weather treatment systems under consideration will also not remove significant amounts of ammonia-N.

Alternative 1 – High Rate Secondary Treatment: This alternative, shown schematically in Figure 9, utilizes high rate ballasted clarification, which requires a chemical coagulant, such as ferric sulfate or aluminum sulfate (alum), microsand, and polymer to remove the colloidal and particulate matter in the wastewater. This process would be combined with a biological adsorption process prior to the ballasted flocculation to improve the removal of the soluble fraction of BOD₅ in the wastewater. This alternative provides 30 minutes of contact time with a low concentration (500 to 1000 mg/L) of mixed liquor suspended solids (MLSS). This process has been successfully demonstrated in recent pilot work conducted at several locations. A paper documenting the success of this process is included at the end of this section. Note that this alternative is conceptually similar to an expansion of the current contact stabilization process, with the exception that conventional clarification is replaced by high-rate ballasted flocculation.

Alternative 2 – Biological Filters: This alternative, shown schematically in Figure 10, utilizes primary sedimentation followed by a coarse bed biologically active sand filter, which combines filtration with biological uptake of the soluble BOD₅ constituents. This process is modeled after a similar process currently in service in Birmingham, Alabama. Prior to filtration, the total suspended solids, scum and grit would be reduced in a primary settling tank. The primary effluent would then be treated in deep-bed, relatively coarse mono-media filters that are designed to support biological activity. During dry weather periods, when the facility is not needed for wet weather operation, secondary effluent from the WCWTP will be diverted to the filters to sustain the biomass. Note that the Birmingham system has sufficient upstream storage to preclude the need to operate these filters for treatment of wet weather flows except in extreme events. Plant personnel report that the filters have not been used for treating wet weather flows for several years, and reliable full-scale operating data is not available. Process modeling is therefore based primarily on results obtained during pilot testing prior to system design.

Alternative 3 – Conventional Treatment: This alternative consists of an expansion of the existing conventional treatment facilities. The additional facilities will include two new grit tanks, one new contact basin, and six new secondary clarifiers. This alternative is shown schematically in Figure 11. Peak flow through the WWTP will be 196 mgd. The wet weather flow equalization basin will be constructed with this alternative as well to attenuate peak flows. Dry weather flow less than 30 mgd and wet weather flow equal to or less than 96 mgd (assuming all treatment units in service) would be treated by the existing permitted contact stabilization treatment process. For flows greater than 96 mgd the additional contact basin and secondary clarifiers will be brought online. The stabilization tanks in the contact stabilization process protect the solids from being washed out during high flows and allow for the WWTP to be operated in a storm flow arrangement resulting in the ability to treat high peak flows and retain solids in the system. This process has been successfully demonstrated on dilute wet weather flows at a similar-sized plant in Oregon. A paper documenting this operation is included at the end of this section.

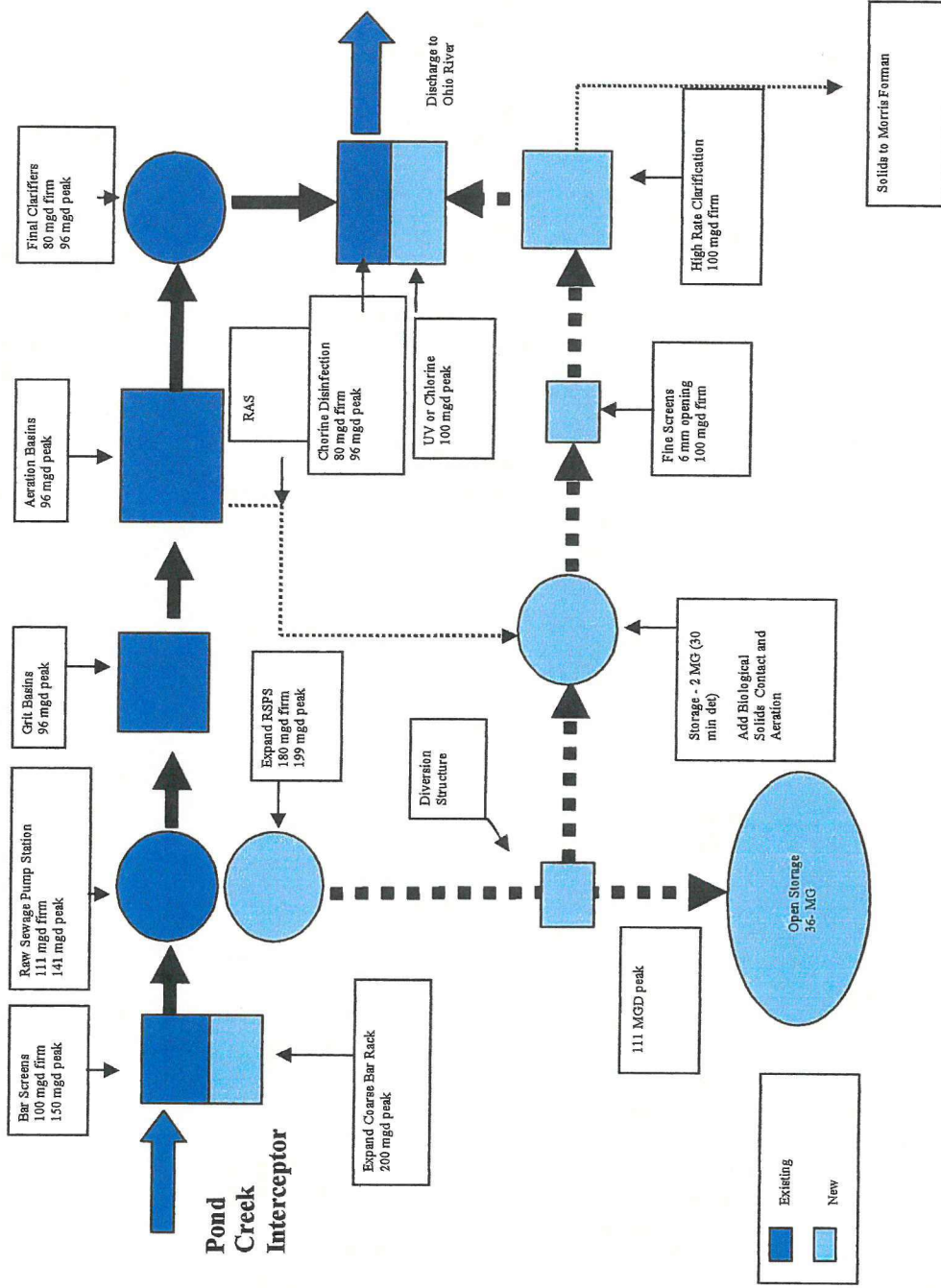

**FIGURE 9-
ALTERNATIVE 1 – HIGH RATE SECONDARY TREATMENT
PROCESS FLOW DIAGRAM**

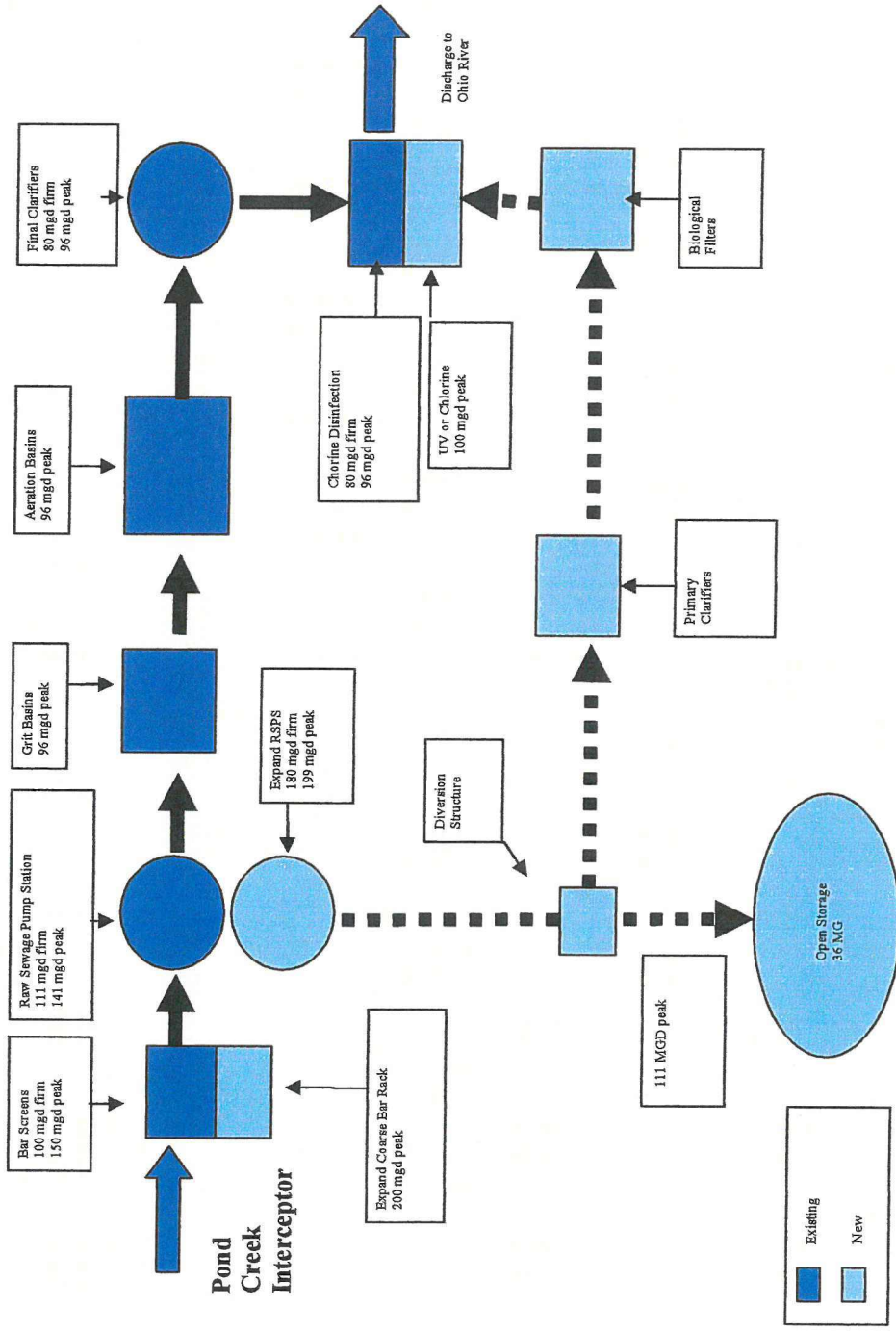
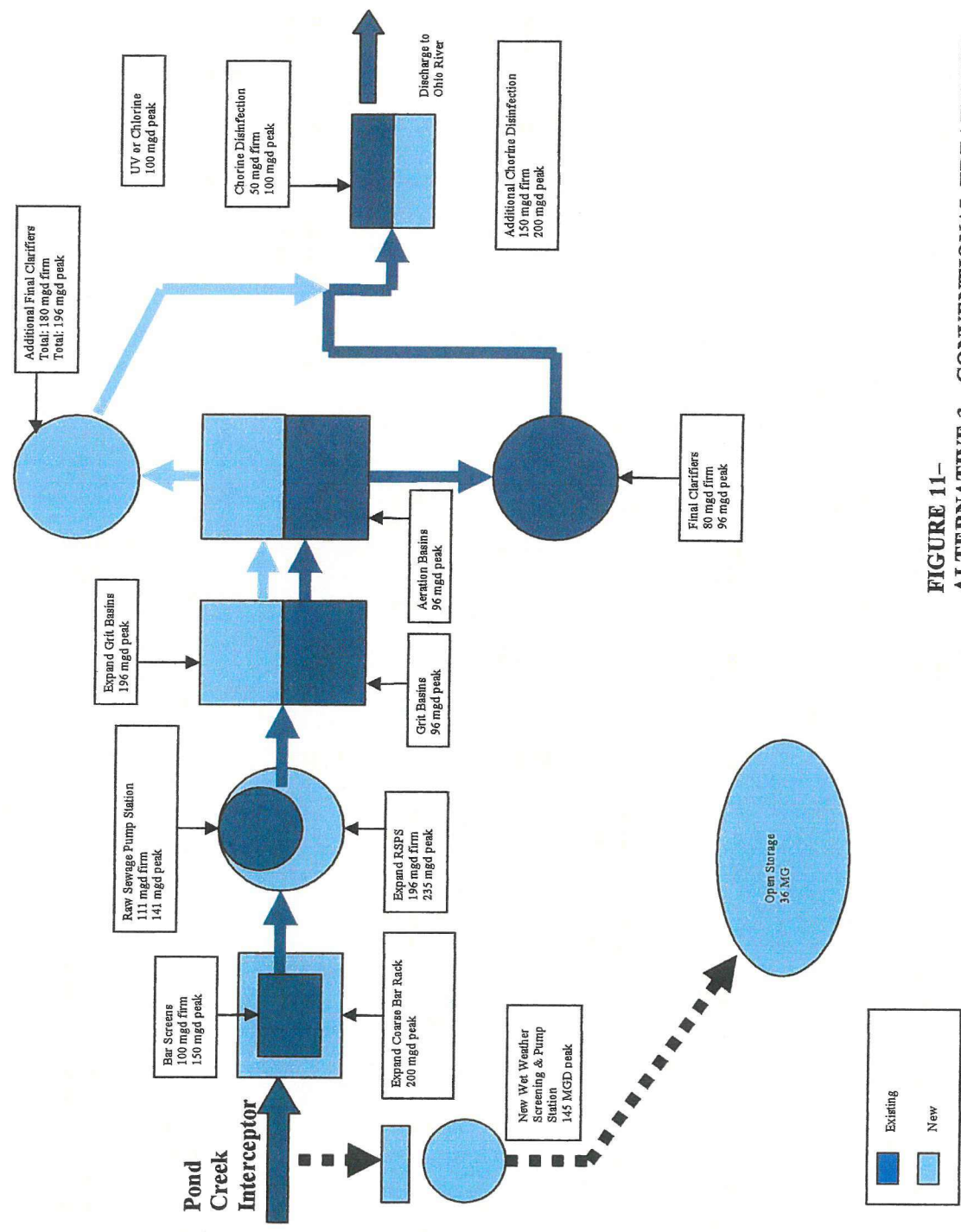

FIGURE 10-
ALTERNATIVE 2 - BIOLOGICAL FILTERS
PROCESS FLOW DIAGRAM



**FIGURE 11-
ALTERNATIVE 3 – CONVENTIONAL TREATMENT
PROCESS FLOW DIAGRAM**



MSD

Louisville and Jefferson County
Metropolitan Sewer District

Interim Sanitary Sewer Discharge Plan (ISSDP)

MARCH 8, 2008

SECTION 2 REFERENCE PAPERS

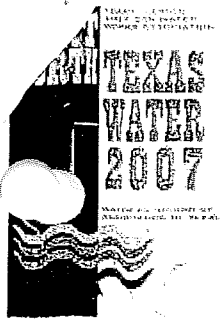

High Rate Secondary Clarification For Wet Weather Applications



Prepared for
Texas Water 2007

April 12, 2007

Prepared by:
Nathen Myers and Randel West, P.E.



I. Kruger Inc.
401 Harrison Oaks Blvd., Suite 100
Cary, NC 27513



Chiang, Patel & Yerby, Inc.
1820 Regal Row, Suite 200
Dallas, TX 75235

Table of Contents

Executive Summary	4
1.0 Technology Overview.....	5
High Rate Clarification (HRC)	5
High Rate Secondary Clarifier (HRSC).....	6
2.0 Murfreesboro, TN	9
Overview	9
Summary	10
3.0 Auburn, AL	12
Overview	12
Summary	13
4.0 Weig Cartonboard Mill, Mayen, Germany	15
Overview	15
Summary	16
5.0 Conclusion	18

List of Figures and Tables

Figure 1.0: ACTIFLO Process Flow Diagram.....	5
Figure 1.1: ACTIFLO [®] High Rate Secondary Clarification Schematic.....	6
Figure 1.2: Example of a High Rate Secondary Clarification Plant Layout.....	7
Table 1.0: HRSC Design Summary	8
Figure 2.0: HRSC Pilot Plant Layout	9
Table 2.0: Murfreesboro HRSC Case Study Results	10
Table 2.1: Murfreesboro HRSC UVT Data	11
Table 2.2: Murfreesboro HRSC Case Study Results without Lamella Tubes.....	11
Table 3.0: Secondary Influent Characteristics	12
Figure 3.0: HRSC Pilot Plant Layout	13
Table 3.1: Results Summary for Varying Overflow Rates	14
Figure 4.0: Plant layout utilized during the case study	15
Figure 4.1: Case Study Data Summary	16

Table 4.0: Full Scale Economic Analysis	16
Figure 4.2: Full Scale Plant Layout including the HRSC.....	17
Table 5.0: HRSC Design Summary	18

List of Abbreviations

BOD:	Biochemical Oxygen Demand
Capex:	Capital Expenditure
COD:	Chemical Oxygen Demand
CSO:	Combined Sewer Overflow
HRC:	High Rate Clarification/Clarifier
HRSC:	High Rate Secondary Clarification/Clarifier
MGD:	Million Gallons per Day
MLSS:	Mixed Liquor Suspended Solids
NTU:	Nephelometric Turbidity Units
Opex:	Operating Expenditure
RAS:	Return Activated Sludge
SSO:	Sanitary Sewer Overflow
SVI:	Sludge Volume Index
TKN:	Total Kjeldahl Nitrogen
TSS:	Total Suspended Solids
UVT:	Ultraviolet Transmissivity
VFD:	Variable Frequency Drive
WAS:	Waste Activated Sludge
WWTP:	Wastewater Treatment Plant

Executive Summary

Many wastewater plants across the country experience operational difficulty during peak wet weather flows caused by storm events. Prolonged peak wet flows can cause problems at plants by hydraulically washing out the biological solids from secondary clarifiers. This causes poor effluent quality during the event and for a period after the storm passes due to a lack of biological solids left in the system. Typical aeration basins can handle large hydraulic events, the hydraulic bottleneck occurs at the secondary clarifier. Additional secondary clarifiers can be constructed to alleviate hydraulic overloading, but these units require large footprints are expensive to build and complicate operation during normal dry weather flows.

The ACTIFLO[®] process is a High Rate Clarification (HRC) process using microsand to ballast flocs and provide rapid settling. Recent pilot study results demonstrate that the HRC process can be successfully applied as a High Rate Secondary Clarification (HRSC) system following activated sludge systems. Sludge production from the HRSC system has a solids concentration comparable to that of traditional secondary clarifiers and is returned back to the biological plant as return activated sludge (RAS). Because the clarified effluent has been biologically treated in the aeration basins, it complies with secondary limits for TSS and BOD. The process also provides a rapid startup time, high peaking capacity, and very small footprint. Since the process reaches steady state conditions in minutes and has a footprint 10 to 15 times smaller than conventional clarifiers it is ideally suited for high rate secondary clarification of mixed liquor produced during peak wet weather flows. Supplementing traditional secondary clarification with high rate sedimentation will enable a treatment facility to sustain peak flows for longer periods of time while minimizing the potential for washout.

During dry weather flows the HRSC trains can be maintained offline. When plant flows reach the hydraulic capacity of the existing secondary clarifiers the HRSC trains are brought on line to treat the additional plant flow from the biological treatment process. Influent MLSS concentrations from the biological process are expected to be as high as 4,000 mg/l, but decrease as the period of a storm is increased.

Pilot studies conducted at a conventional municipal wastewater treatment facility and an industrial wastewater treatment facility employing biological treatment demonstrated the efficiency of the process. During the municipal wastewater study, the process received mixed liquor suspended solids at concentrations between 2,600 and 3,000 mg/l. Settled effluent from the process averaged less than 10 mg/l TSS and less than 5 mg/l BOD. During the industrial pilot study, the process received MLSS between 5,000 and 6,000 mg/l and the clarified effluent averaged less than 30 mg/l TSS. This paper details the operating conditions and results of these studies.

1.0 Technology Overview

High Rate Clarification (HRC)

The HRC design is an ACTIFLO[®] process supplied by I. Kruger Inc. Cary, NC. The process is a proven, high performance, compact clarification system that utilizes micro-sand enhanced flocculation and settling. The microsand also enhances system stability, enabling the HRC process to produce a consistent high quality effluent despite changing raw water conditions such as flow rate or solids content. A coagulant is added to the raw water for destabilization of the colloids. The coagulated water then goes through a two-stage flocculation where micro-sand and polymer are added. The destabilized suspended solids bind to the micro-sand particles through polymer bridges creating extremely dense floc particles, which have excellent settling characteristics. This permits clarifier designs that have much shorter hydraulic retention times and much higher surface loading rates compared to conventional clarifiers. With the additional aid of lamellar settling tubes, the micro-sand ballasted floc particles then settle very rapidly. The sludge/micro-sand mixture collected at the bottom of the tube settler is continuously pumped by open-end centrifugal pumps to hydrocyclones, which separate the micro-sand from the residuals by the centrifugal force of the vortex action. The residuals are then discharged and the micro-sand is reinjected into the system. A general HRC process diagram is depicted in figure 1.0.

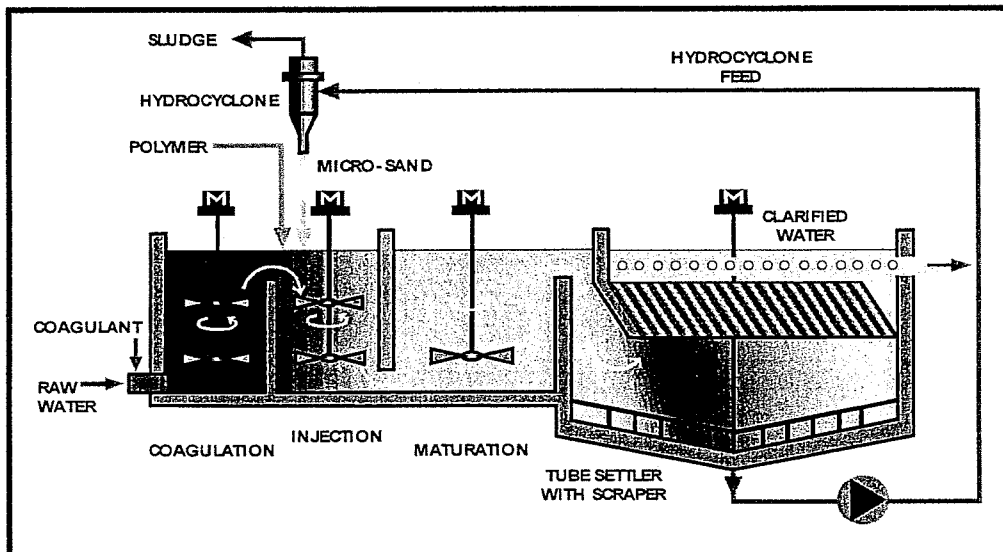

Figure 1.0: ACTIFLO Process Flow Diagram

The ACTIFLO[®] process has been successfully applied to treat wet weather flows in parallel with existing wastewater treatment plants. These plants experienced limited peaking capacity of the biological process and have limited available space for traditional treatment options. The HRC process has also been used as a satellite treatment facility located in the collection system in situations where active overflows cannot be effectively delivered to a central treatment facility. These designs protect the wastewater treatment plants from washout of secondary

treatment processes, effluent degradation, and slow treatment recovery. There are presently 14 ACTIFLO® wet weather treatment facilities in the United States.

High Rate Secondary Clarifier (HRSC)

Enhancements to the HRC system have demonstrated that the ACTIFLO® process can be successfully applied as a high rate secondary clarification system. Sludge production from the HRSC system has a solids content comparable to that of traditional secondary clarifiers and is readily returned back to the biological plant as return activated sludge (RAS). This design complies with secondary limits for TSS and BOD. The design also provides a rapid startup time, high peaking capacity, and very small footprint. Since the process reaches steady state conditions in minutes and has a footprint 10-15 times smaller than conventional clarifiers it is ideally suited for high rate secondary clarification of mixed liquor produced during peak wet weather flows. Figure 1.1 illustrates a typical flow diagram.

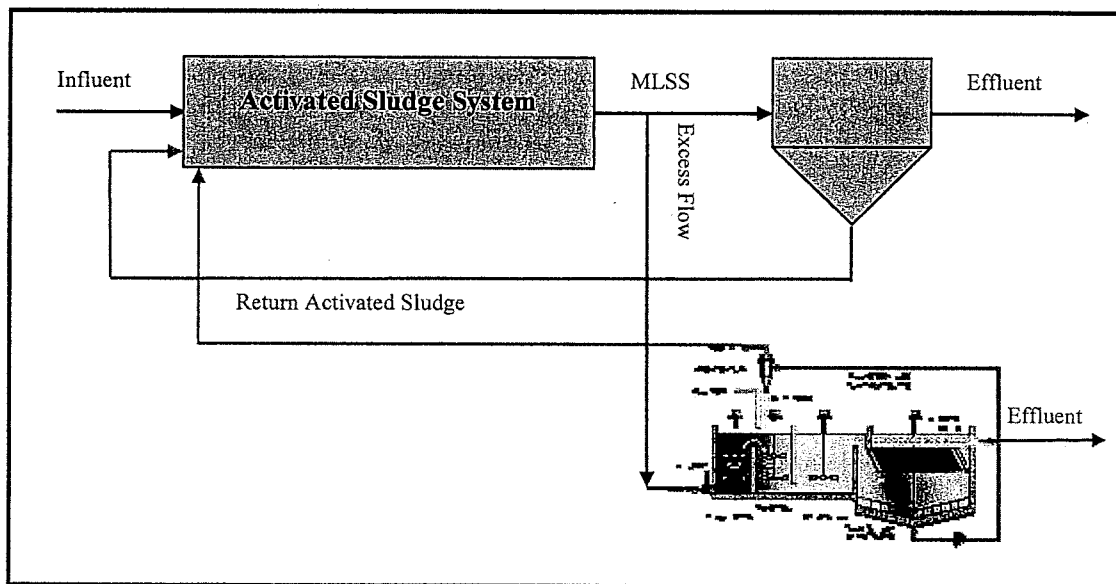

Figure 1.1: ACTIFLO® High Rate Secondary Clarification Schematic

During dry weather flows the HRSC trains can be maintained offline. When plant flows begin to reach the hydraulic capacity of the existing secondary clarifiers the HRSC trains are brought on line to treat the additional plant flow from the biological treatment process. The expected influent MLSS concentrations from the biological process are expected to be approximately 4,000 mg/l.

A dosage of coagulant is added to the influent stream prior to entering the HRSC process. The coagulated water then enters a coagulation tank for first stage mixing. Coagulant destabilizes the suspended solids and colloidal matter in the influent stream. Efficient mixing is provided in the coagulation tank to thoroughly disperse the coagulant over a hydraulic retention time of approximately 5 minutes. The destabilized particles collide and begin early stage floc formation.

The coagulated water then flows over a weir into an injection mixing tank where flocculent aid polymer and microsand are added to initiate floc formation. Here, the combination of flash mixing and a hydraulic retention time of approximately 5 minutes allow for thorough incorporation of microsand ballast and polymer into the coagulated water. The combination of microsand and polymer serve as a “seed” for floc formation and development in the next process step.

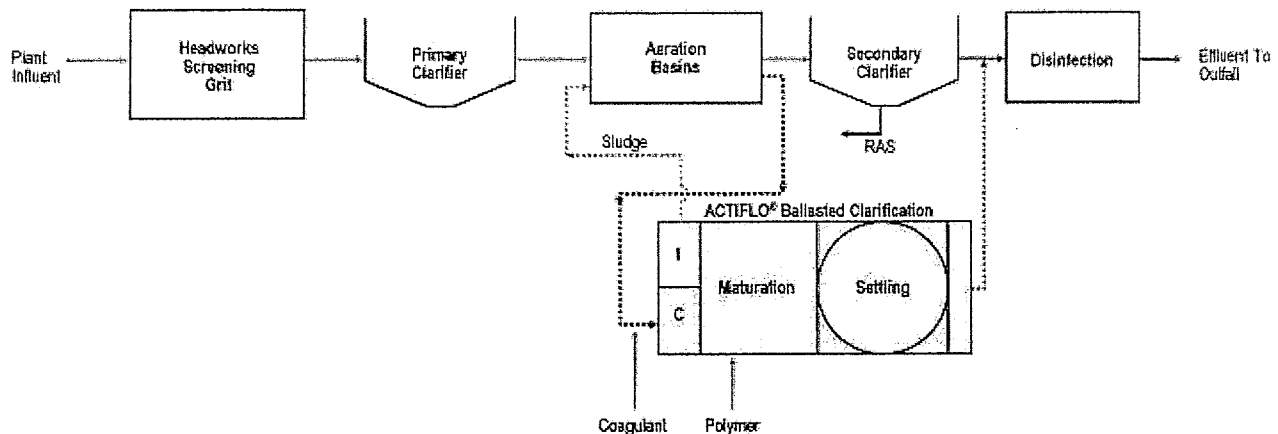

Figure 1.2: Example of a High Rate Secondary Clarification Plant Layout

HRSC treatment continues as water passes through the underflow passage from the injection tank into the maturation tank. Although chemical floc formation actually begins with the addition of polymer and microsand in the injection tank, the majority of ballasted floc formation occurs during the maturation process step. Gentle mixing and increased hydraulic retention time of approximately 15 minutes provide ideal conditions for the formation of polymer bridges between the microsand and the destabilized suspended solids. The large effective surface area of the microsand provides enhanced opportunity for polymer bridging and enmeshment of microsand and floc already in suspension.

The fully formed ballasted floc particles leave the maturation tank and enter the settling tank. Here the ballasted flocs rapidly settle and are removed from the flow stream. Laminar upflow through the settling zone provides rapid and effective removal of the microsand/sludge floc. Due to the settling properties of the ballasted floc, plate settlers are not required in the settling tank. Clarified water exits the ACTIFLO® process via a series of collection troughs with weirs for subsequent downstream treatment or discharge.

The ballasted floc sand-sludge mixture is collected at the bottom of the settling tank, moved to the center collection pit via a scraper mechanism and withdrawn using a rubber-lined centrifugal slurry pump. The sand-sludge mixture is then pumped to the hydrocyclone for separation. Energy from pumping is effectively converted to centrifugal forces within the body of the hydrocyclone causing the sludge to be separated from the higher density microsand. Once separated, the microsand is concentrated and discharged from the bottom of the hydrocyclone and re-injected into the HRSC process for re-use. The lighter density sludge is discharged out the top of the hydrocyclone and sent back to the biological process as return activated sludge

(RAS) or sent to waste (WAS). Solids concentration in the hydrocyclone sludge varies between 2 to 4 times the HRSC influent MLSS concentration.

Table 1.0: HRSC Design Summary

Variable	Value
Raw Water MLSS	Up to 4000 mg/l
Coagulation/Flocculation Time	15-20 min.
Nominal Overflow Rate	10-25 gpm/ft ²
Recirculation Rate	20 to 30 %
Sludge Concentration	8,000-16,000 mg/l
Effluent TSS	<10 mg/l
Effluent BOD	<10 mg/l*
Total P	>90% removal
Coagulant Dosage	<10 mg/l
Polymer Dosage	5-20 mg/l
Sand Consumption	16-48 lbs/MG treated

*BOD removal efficiencies are estimates and dependent upon specific biological plant design and operating conditions

NOTE: NH₃-N removal efficiencies should be evaluated on a case-by-case basis.

2.0 Murfreesboro, TN

Overview

I. Kruger, Inc. performed a HRSC case study to evaluate the MLSS treatment efficiency from aeration basins located at the Sinking Creek Wastewater Treatment Plant in Murfreesboro, Tennessee. The Sinking Creek WWTP has limited capacity to treat the excess flows experienced during wet weather CSO events. The plant would like to expand their existing secondary clarification capacity for use during wet weather events and also evaluate the possibility of utilizing the HRSC process as a side stream operation during non wet weather events. Figure 2.0 illustrates the case study layout performed at the Sinking Creek WWTP.

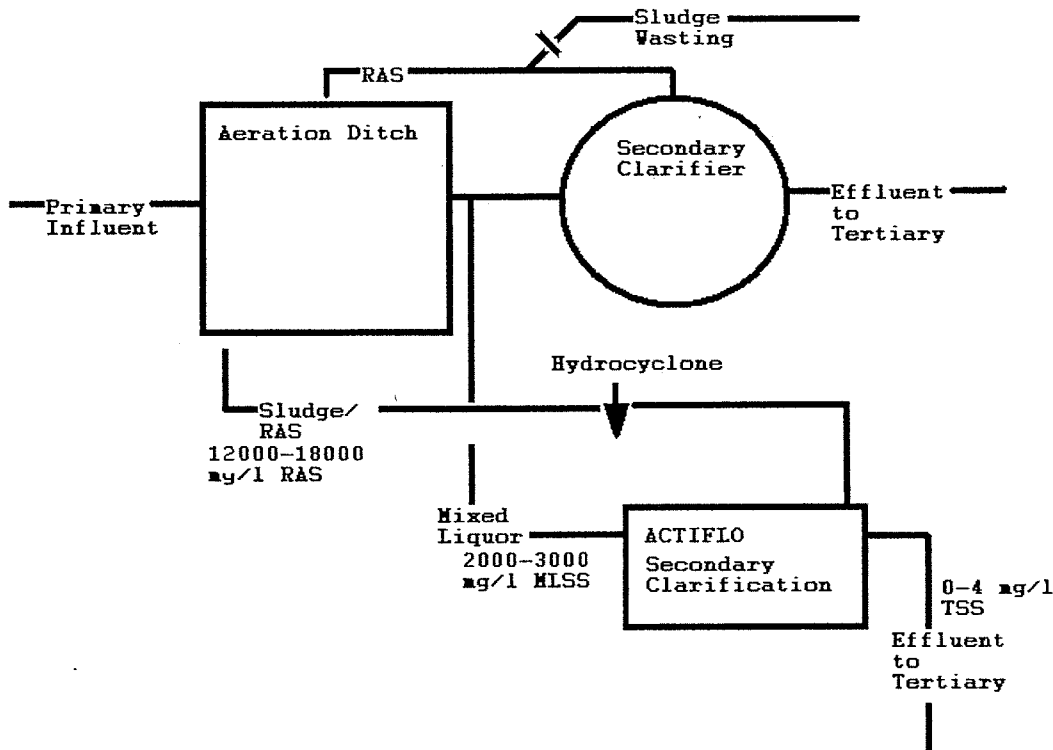

Figure 2.0: HRSC Pilot Plant Layout

The testing period for this case study lasted for two (2) months starting in January 2005. Over the course of the study, turbidity, pH, and alkalinity were monitored in the field, while TSS, BOD, Phosphorous, and Iron were collected for lab analysis. The testing conditions for this study adhered to the following:

Operating Parameters

- Loading Rate: 9 and 15 gpm/ft²
- HRT: 30 and 45 minutes
- Recirculation Rates: 17 and 25 gpm
- Raw Turbidities: 1,100 – 2,100 NTU
- Raw TSS: 2,500 – 3,290 mg/l
- Raw Total P: 22 – 84 mg/l
- Raw BOD: 154 mg/l
- RAS 12,000 – 18,000 mg/l

Chemical Dosages:

- Ferric Sulfate: 5 – 13 mg/l
- Ferric Chloride: 8 – 15 mg/l
- ACH: 3 – 10 mg/l
- No Coagulant
- Cationic Emulsion: 4 – 14 mg/l

Summary

The HRSC process proved that it could meet and exceed all the goals set forth for this pilot study. The three coagulants that were evaluated in conjunction with the cationic emulsion polymer proved to meet and exceed the set objectives. In addition, the HRSC was able to demonstrate successful treatment with polymer alone between doses of 12.0 and 14.0 mg/l.

Once the HRSC system was optimized, effluent turbidities less than 2 NTU were consistently maintained. Turbidity removals during the study averaged 99.9 % and TSS removals averaged 99.9 %. Phosphorous removals averaged 96.7 % while BOD removals averaged 98.3 % with an average effluent BOD of 2.73 mg/l. TSS associated with the sludge was also monitored during this study since the sludge from the HRSC system would be sent back to the oxidation ditch as RAS. Sludge TSS needed to range between 12,000 mg/l to 18,000 mg/l. The solids in the sludge were maintained within the range specified at the different overflow rates by varying the sand recirculation rates. Table 2.0 provides a performance summary realized during the case study.

Table 2.0: Murfreesboro HRSC Case Study Results

Coag. Type	Dose mg/l	Poly Dose*	NTU		TSS*		Phosphorous*		BOD*	
			Raw	Effluent	Raw	Effluent	Raw	Effluent	Raw	Effluent
Fe ₂ SO ₄	13	14	1,615	1.4	2,731	8.8	55.4	0.83	154	1.1
ACH	5	14	1,784	1.2	2,840	5.8	65.0	2.33	154	4.3
No Coag.	--	14	1,714	1.4	2,883	9.0	53.3	2.49	150	1.6
Plant Secondary	--	--	1,442	1.4	2,619	7.4	60.3	2.57	154	2.0

*Units are in mg/l

Note: The averaged data collected from the plant's secondary clarifier reflects an overflow rate of 1 gpm/ft² compared to the data obtained from the HRSC with overflow rates of 9 to 15 times greater with similar or better results.

In evaluating different coagulants, there was no significant difference in treatment efficiency regarding any of the parameters being monitored. Additionally, operating with no coagulant and increasing the polymer yielded similar removal rates. While dosing Ferric Sulfate at 13 mg/l, effluent iron samples were taken to ensure levels were low so not to interfere with the downstream UV system. Influent iron measured 18 mg/l, effluent iron measured 0.12 mg/l and iron in the sand being returned in the system measured 13 mg/l. HRSC effluent samples were also sent to Trojan Technologies for UVT analysis and the percent transmittance averaged 78 % (see table 2.1 for analysis results).

Table 2.1: Murfreesboro HRSC UVT Data

SAMPLE NO.	SAMPLE DESCRIPTION	%T	%T FILTERED	TSS (PPM)
S05-117	Actiflo Effluent, 10mg/L $Fe_2(SO_4)_3$, 10mg/L KILL Cationic Polymer	78	79	1
S05-118	Actiflo Effluent, 0mg/L $Fe_2(SO_4)_3$, 10mg/L KILL Cationic Polymer	77	78	5
S05-119	Actiflo Effluent, 0mg/L $Fe_2(SO_4)_3$, 13mg/L KILL Cationic Polymer	78	78	<1
S05-120	Secondary Effluent (PSE 1A) #4 Clarifier	78	78	1
S05-121	MWSD, SCWWTP – Filtered F1	78	78	2

Additional testing to evaluate settling efficiencies was performed at overflow rates between 9 and 15 gpm/ft² without lamella tubes in the settling tank. ACH, Ferric Sulfate, and no coagulant were evaluated with a cationic emulsion polymer (see table 2.2 for performance details).

Table 2.2: Murfreesboro HRSC Case Study Results without Lamella Tubes

Coag. Type	Dose mg/l	Poly Dose*	NTU		TSS*		Phosphorous*	
			Raw	Effluent	Raw	Effluent	Raw	Effluent
ACH	10	14	1,830	1.25	2,740	0	48	2.6
Fe_2SO_4	8	14	2,004	1.75	2,740	0	54	1.9
No Coag.	--	14	1,967	1.88	2,825	0	59.5	2.9

*Units are in mg/l

3.0 Auburn, AL

Overview

A case study to demonstrate the reliability, operation efficiency and associated cost benefits was performed by I. Kruger Inc at the H.C. Morgan Wastewater Treatment Plant located in Auburn, Alabama. The testing period began in late September 2005 and lasted for more than two (2) months. Data collected from past case studies proved that a HRSC can successfully operate at an overflow rates of 12 gpm/ft². This data served as a reference for establishing a base line of operating parameters particularly in investigating peak overflow rates and optimum treatment.

After establishing initial treatment, overflow rates were increased and the performance of the process was evaluated using turbidity, Total Suspended Solids (TSS) and Biochemical Oxygen Demand (BOD). These parameters were monitored to establish chemical dosages and sand recirculation rate.

To simulate excess flow resulting from a CSO event, the secondary influent MLSS was diluted with the secondary effluent before entering the HRSC. Dilutions rates of 20, 30 & 50 % were analyzed during the study (see table 3.0). Turbidity was used as an indicator for dilution rates. Once operating parameters were optimized for each dilution, extended runs were conducted to evaluate impacts of the settled sludge return on the stability of the conventional process. The results demonstrated that extended periods of operation did not affect the overall water quality of the secondary effluent.

Table 3.0: Secondary Influent Characteristics

Parameter	Concentration			
	No Dilution*	50% Dilution	30% Dilution	20% Dilution
Turbidity (NTU)	2,500 – 3,000	1,600 – 1,800	920 – 1,020	500 – 550
BOD (mg/l)	200 – 300	184 – 396	123 – 396	66.5 – 196
TSS (mg/l)	2,500 – 4,500	1,300 – 2,500	1,600 – 1,800	1,000 – 1,100

*Represents the water characteristics of the primary clarifiers

Once all parameters for secondary clarification were completed the pilot unit was relocated to the head works to access primary influent. Figure 3.0 reflects the case study layout for both the secondary and primary operations.

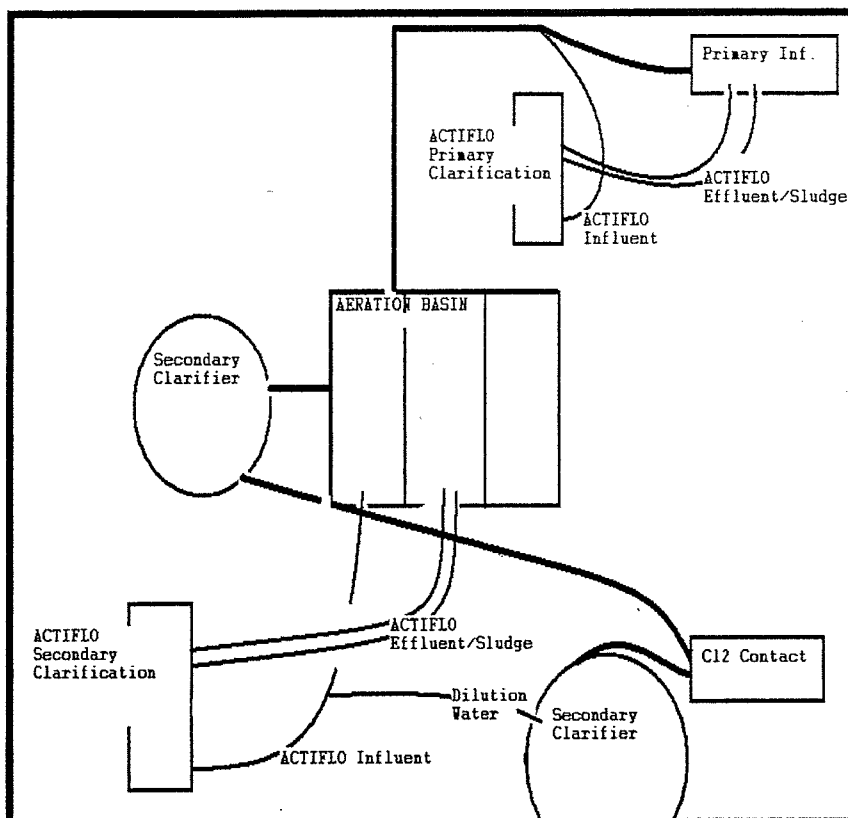

Figure 3.0: HRSC Pilot Plant Layout

Summary

Baseline operations of 12 gpm/ft² reflected optimum treatment using ferric chloride (FeCl₃) between 5 and 10 mg/l and a cationic polymer at 12 mg/l. As overflow rates were increased throughout the study, coagulant dosages remained constant at 5 to 10 mg/l. Polymer dosages and sand recirculation however increased in accordance with the increased solids loading rate. At 24 gpm/ft² a coagulant dose of 5 mg/l of FeCl₃ and a dose of 24 mg/l of cationic polymer was applied, along with a recirculation rate of 31-33 % for steady treatment. Turbidity removals in excess of 99 % and a TSS removal in excess of 99 % were achieved at these parameters. During optimization up to 99 % removal of BOD was achieved.

During optimization it was established that polymer was one of the key constituent in treatment. It is important to note that overflow rates directly correlate with polymer doses and recirculation rates. At 15 gpm/ft² a polymer dose of 15 mg/l was needed to obtain steady treatment. During the dilution phase of the secondary clarification turbidities remained at or below 2 NTU. All tested parameters met excellent removals, polymer doses did decrease as diluted secondary influent decreased. At a 50 % dilution only 12 mg/l of polymer was needed to maintain treatment at 24 gpm/ft². A 30 % dilution was evaluated and polymer dosages remained constant at 12 mg/l, but decreased to 8 mg/l at 20 gpm/ft².

Recirculation rates and sand concentrations were also evaluated as process parameters. Recirculation rates varied in accordance with the overflow rates and MLSS concentrations. Initial testing of 4,000 mg/l MLSS, a recirculation rate of 27 % was used to establish treatment at 15 gpm/ft². Recirculation rates were increased to 29 % at 17 gpm/ft² and 38 % at 24 gpm/ft² to accommodate the increased solids. During the dilution phase the recirculation rate remained at 38 % for a mixed liquor concentration of 2,500 mg/l and decreased to 33 % at lower mixed liquor concentrations of 1,750 and 1,000 mg/l.

Turbidity removals were used as a quick reference for treatment during optimization and were also used for treatment stability during extended runs. Approximately 2 NTU was used as a reference point to gain initial treatment. At overflow rates of 15, 17, and 24 gpm/ft², less than 2 NTU turbidity from raw water turbidities between 2,500 and 3,500 NTU was achieved throughout each extended run. This represents greater than 99.9 % removal.

TSS removals were relatively consistent throughout all extended run phases of secondary testing. Although dilutions varied, removals greater than 99 % were observed during every extended run including the dilutions phases.

BOD removal of 99 % was recorded for overflow rates of 15 and 17 gpm/ft². No data was collected at 24 gpm/ft² due to time constraints on lab personnel. Dilutions of 30 % and 50 % produced greater than 99 % removal but decreased during the 20 % dilution extended run. BOD was also collected throughout an eight-hour period as a composite sample to test for consistencies and stability. Table 3.1 summarizes the average data obtained at optimum conditions.

Table 3.1: Results Summary for Varying Overflow Rates

Overflow Rate gpm/ft ²	TSS*		BOD*		Ammonia*		TKN*		Phosphorous*	
	Raw	Effluent	Raw	Effluent	Raw	Effluent	Raw	Effluent	Raw	Effluent
15	4,100	6	354	1	0.32	0.03	150	1.3	140	0.1
17	3,880	2	216	1	0.19	0.03	180	0.66	140	0.17
24	3,015	6	--	--	7.6	0.03	35	1.7	40	0.3

*Units are in mg/l

NOTE: All data represents optimum conditions using a FeCl₃ dose between 5 and 10 mg/l and a cationic polymer dose less than 15 mg/l

During the primary clarification phase of testing, ferric chloride (FeCl₃) and aluminum sulfate (Al₂(SO₄)₃). Both coagulants had similar results in regards to turbidity, TSS, and BOD removals. Both coagulants performed under optimum conditions at 85 mg/l. In addition to the coagulants, an anionic polymer was evaluated. It was established that 2.5 mg/l of polymer was needed to gain treatment at the established overflow rates with both coagulants. Both NTU and TSS removals were greater than 95 % and BOD exceeded 75 % removal.

4.0 Weig Cartonboard Mill, Mayen, Germany

Overview

Two (2) case studies were performed at the Weig cardboard mill located in Mayen, Germany. The first occurred in September 2002 for one (1) month and the second took place in October 2005 for approximately one (1) month to demonstrate secondary clarification. The plant processes 600,000 tons per year of recycled paper and uses a combination of surface and ground water as its fresh water source. Due to a production increase, the mill must increase the wastewater treatment capacity while reducing TSS. The existing secondary clarifier is operating at maximum capacity and constraints in the available space cannot support expanding the existing treatment process. Due to the footprint limitations, the case study was limited to only technologies that could feasibly fit in the proposed full scale location. Figure 4.0 illustrates the case study layout within the existing plant. Two technologies were chosen based on this limiting factor, which included the HRSC and submerged membranes. Both technologies were evaluated on treatment ability and cost associated with capital, operations, and installation. The treatment goal required a reduction of TSS between 4,000 to 6,000 mg/l to less than 30 mg/l. Operating parameters associated with the HRSC included the following:

Operating Parameters:

- No Lamella: Removed to avoid sludge build-up & floc carry over
- Overflow Rate: 13.5 gpm/ft²
- HRT: 10 to 15 minutes
- Raw TSS: 5,000 – 6,500 mg/l
- Sludge Discharge: 28 – 32 % of influent flow
- Sludge Concentration: 1.5 – 2.0 % solids

Chemical Dosages:

- No coagulant added: Client adds ~ 20 mg/l of Fe(II) in aeration tank for P removal
- Coag. Aid Polymer: 4 – 5 mg/l active PolyDADMAC
- Polymer: Cationic Polymer at 4 mg/l

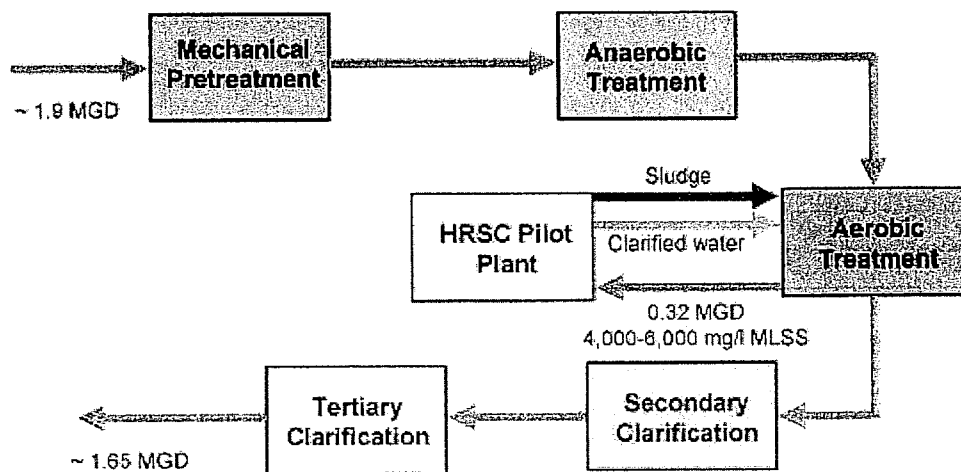

Figure 4.0: Plant layout utilized during the case study

Summary

During the study, the HRSC was able to prove successful treatment based on the set objectives. Figure 4.1 illustrates the data obtained during the testing period. The data is separated into six (6) phases. Phases I, II, III, IV, and V are considered optimization phases while phase VI illustrate the effectiveness of the HRSC to treat under the desired parameters.

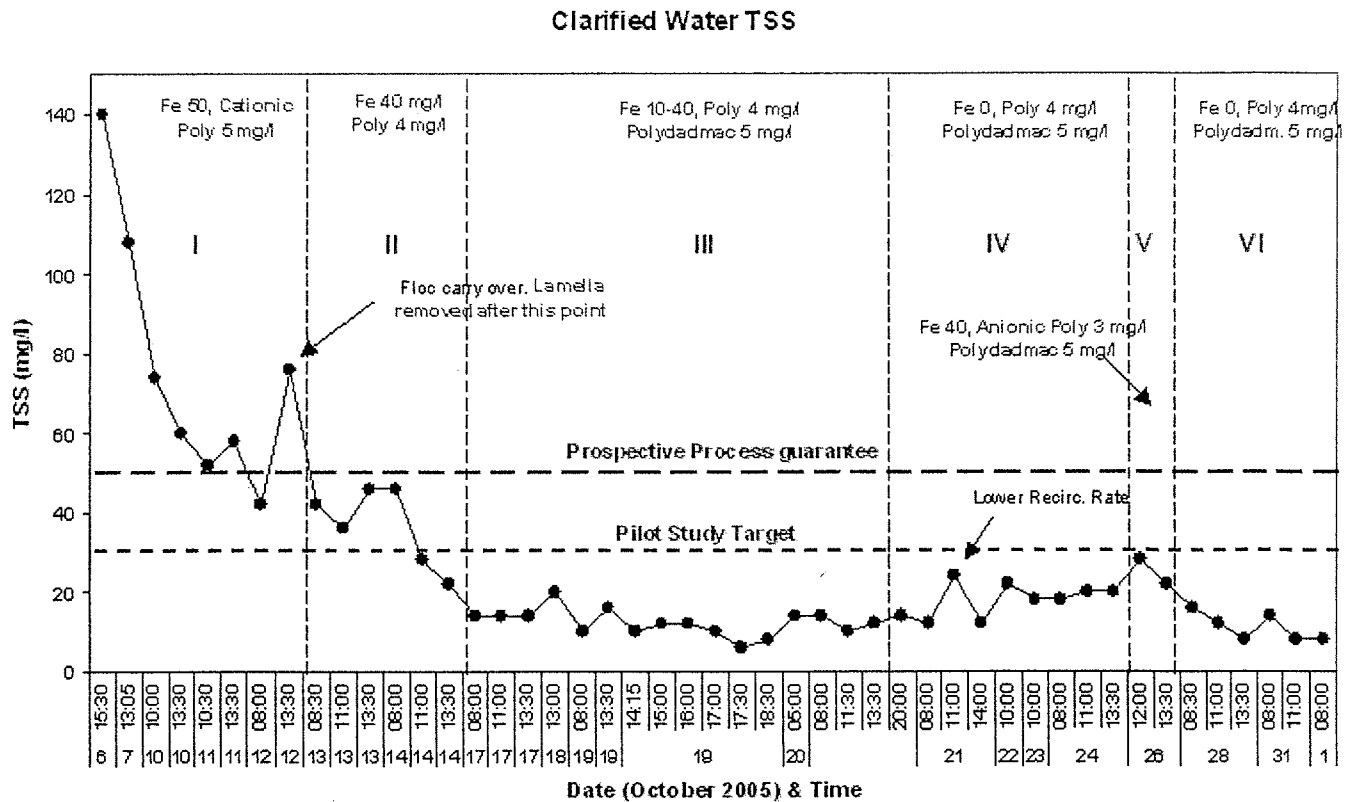

Figure 4.1: Case Study Data Summary

Based on these favorable results and a complete economic evaluation, Weig decided to employ the ACTIFLO® process for the full scale HRSC design. The economic analysis reflected the information provided in table 4.0.

Table 4.0: Full Scale Economic Analysis

Variable	HRSC	Membranes
Capital Equipment	840,000	2,160,000
Installation ⁽¹⁾	840,000	480,000
Total Capex	1,680,000	2,640,000
Total Opex	192,000 ⁽²⁾	276,000 ⁽³⁾

NOTE: all cost were calculated using an exchange rate average for March 2006 of 1 Euro = 1.2 American dollars

(1): Includes electrical and civil

(2): Includes chemicals, energy, manpower, and spare parts

(3): Includes energy, manpower, and membrane replacement

The Capex (Capital Expenditure) associated with the HRSC included additional scope items representing a complete equipment package. The final HRSC design as illustrated in figure 4.2 was based on proven pilot data as described in the following list:

Operating Parameters:

- Sand concentration: 30 – 40 g/l to account for high TSS
- Mixers: Included VFDs for proper speed control
- No lamella: Removed to avoid sludge build-up and floc carry-over
- Design overflow rate: 13.5 gpm/ft²
- Sludge discharge: 28 – 32 % of influent flow
- Sludge Concentration: 1.5 – 2.0 % solids

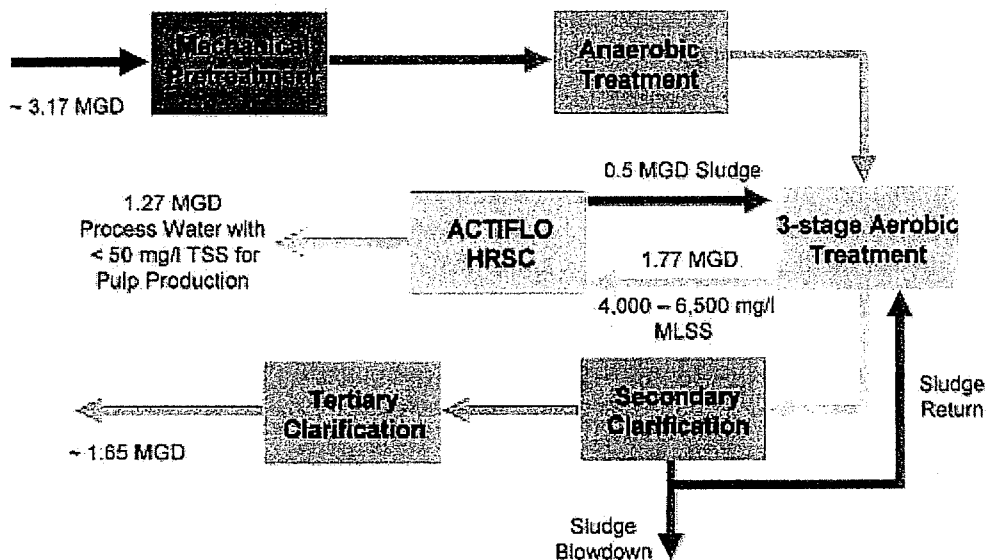

Figure 4.2: Full Scale Plant Layout including the HRSC

Since startup in July 2006, the HRSC has successfully operated and maintain treatment according to the process guarantee. Full scale HRSC results at the Weig mill reflect the following:

Full Scale Results

- Influent TSS: 4,000 – 6,500 mg/l (Activated Sludge)
- Effluent TSS: 10 – 35 mg/l
- Effluent Turbidity: 5 – 33 NTU

Chemical Dosages:

- No coagulant: Client adds ~ 20 mg/l of Fe(II) in aeration tanks for P removal)
- Coagulant Aid: 4 – 5 mg/l active PolyDADMAC
- Cationic Polymer: 4 – 7 mg/l depending on SVI (Sludge Volume Index)

5.0 Conclusion

Data collected from the case studies mentioned in this paper were used to evaluate the ACTIFLO® process for high rate secondary clarification (HRSC). The purpose of these studies was to establish a base line of operating parameters particularly investigating peak overflow rates. Throughout each of the studies, overflow rates were increased and evaluated using turbidity, TSS and BOD. These parameters served as the basis to establish chemical dosages and sand recirculation rate. It was documented that overflow rates directly correlated with polymer doses and recirculation rates.

During initial testing of the HRSC, a MLSS concentration was evaluated at varying overflow rates. As overflow rates increased, coagulant dosages remained constant. A ferric-based coagulant proved to be more efficient and stable in regards to treatment. To simulate a wet weather event, the secondary influent was diluted with the secondary effluent before entering the HRSC. Each of the dilutions tested required similar ferric dosages. As dilutions were evaluated it was observed that a polymer dosage was affected directly by MLSS concentration. As the MLSS concentration was reduced the polymer demand was also reduced. Recirculation rates increased in parallel with the increased loading rates and this can be expected due to the augmented applied solids. As applied solids increased within the HRSC the solids removal demand must be met. If the demand was not met solids had a propensity to increase in the system over time causing a need for an increased recirculation rate. Overflow rates and mixed liquor concentrations both had a direct effect on the recirculation rate. As overflow rates increased the recirculation rates increased. Table 5.0 illustrates the optimum conditions obtained from each of the case studies.

Table 5.0: HRSC Design Summary

Variable	Value
Raw Water MLSS	Up to 4000 mg/l
Coagulation/Flocculation Time	15-20 min.
Nominal Overflow Rate	10-25 gpm/ft ²
Recirculation Rate	20 to 30 %
Sludge Concentration	8,000-16,000 mg/l
Effluent TSS	<10 mg/l
Effluent BOD	<10 mg/l*
Total P	>90% removal
Coagulant Dosage	<10 mg/l
Polymer Dosage	5-20 mg/l
Sand Consumption	16-48 lbs/MG treated

*BOD removal efficiencies are estimates and dependent upon specific biological plant design and operating conditions

NOTE: NH₃-N removal efficiencies should be evaluated on a case-by-case basis.

Loading rates for conventional secondary clarifiers range on average from 1 to 2 gpm/ft². Utilizing a HRSC can increase these overflow rates by expanding the capacity of the conventional RAS system. In addition to this application, the HRSC can also be operated during non-wet weather events to treat primary influent, filter backwash, or treat phosphorous by operating in tertiary mode. Additional design details will need to be considered in order to operate under these conditions; however this gives a plant greater functionality when considering what technology is best suited for wet weather applications.

FULL SCALE HIGH RATE WET WEATHER BIOLOGICAL CONTACT PERFORMANCE

Bruce R. Johnson/CH2M HILL, Mike Mengelkoch/Clean Water Services, Rob Baur/Clean Water Services

ABSTRACT

The Durham AWTF in Tigard, OR experiences peak wet weather flows in excess of five times the average dry weather flow. Historically these high peak flows have been handled with a combination of peak flow equalization and step feeding the bioreactor system. In 2005 CH2M HILL suggested the plant try a new operating mode where primary effluent is added to the last zone of the aeration basins, a version of contact stabilization, during high wet weather events. Contact times during the peak flow events were at about 60 minutes. Operating experience with this mode showed excellent BOD and TSS removal. This operating mode increases plant secondary treatment capacity from approximately 70 MGD to at least 100 MGD with no degradation in effluent quality. These results have shown the viability of high rate biological contact in both conventional secondary treatment systems and in dedicated wet weather treatment facilities.

KEYWORDS

Wet Weather, High Rate, Biological Contact

INTRODUCTIONS

The Durham AWTF in Tigard, Oregon is run by Clean Water Services. The Durham plant is rated at 27 MGD during the summer season. During the dry season the plant targets high level nutrient removal (<0.1 mg TP/L and <0.1 mg NH₃-N/L. During the wet season (November through April) the plant does not have any nutrient limits and thus operates for only carbon and total suspended solids (TSS) removal (10/10 limits). During the wet season the Durham AWTF has a peak hour flow peaking factor (Peak Hour/Average Dry Weather) of 5.7. This very high peaking factor results in difficult operations during the peak wet weather events. The plant is design to equalize some of the peak flows and blend the remaining amount not treatable in the secondary treatment system (when the equalization system is full).

HISTORICAL WET WEATHER TREATMENT METHODS

The Durham AWTF liquids treatment system consists of headworks, primary clarification, activated sludge secondary treatment, tertiary clarification, multi-media filtration, disinfection and dechlorination. During the wet season, no alum is added to the tertiary system, but all secondary effluent is passed through the clarifiers and sand filters prior to discharge. All wet weather flows receive preliminary and primary treatment. Wet weather flows in excess of the

secondary treatment capacity are disinfected and diverted to the equalization system and stored for later treatment. If the equalization system fills, excess flow is dechlorinated and discharged in an independent wet weather outfall.

The secondary treatment system consists of four fully independent biological treatment systems operated in parallel. Each treatment train has seven cells, and includes the capability of feeding either the first, second, third, or seventh cell. Figure 1 shows the general bioreactor configuration for the Durham AWTF. The four trains each have minor variations in the design, but the basic functionality is the same. Each train has a total volume of approximately 2.1 MG and a single dedicated 145 foot diameter secondary clarifier.

Figure 1: General Bioreactor Layout

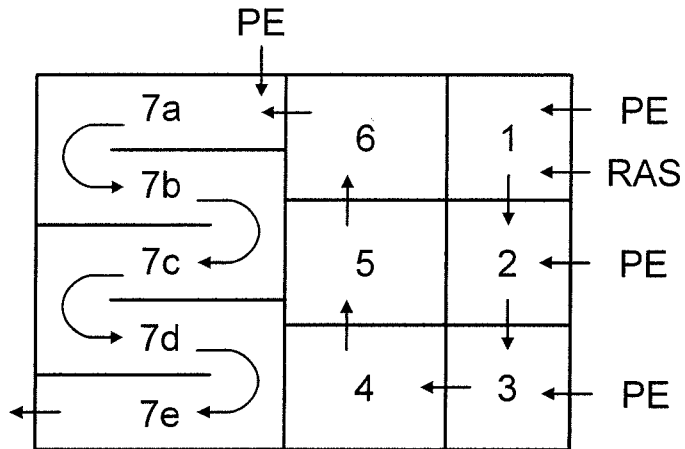

Historically, plant staff converted from Cell 1 feed to Cell 3 feed when the plant flows reached approximately 50 to 60 MGD (average wet weather flows are 28 MGD). At flows of approximately 70 MGD, primary effluent would be diverted to the surge basins, chlorine added for disinfection, and stored in the 8 MG surge basins. At 60 MGD with Cell 1 feed the HRT in the secondary treatment system is approximately 3.4 hours. At 70 MGD with Cell 3 feed the HRT is approximately 2.6 hours. Figure 2 shows an illustration of the two historical wet weather operating modes.

Figure 2: Durham AWTF Wet Weather Bioreactor Configurations

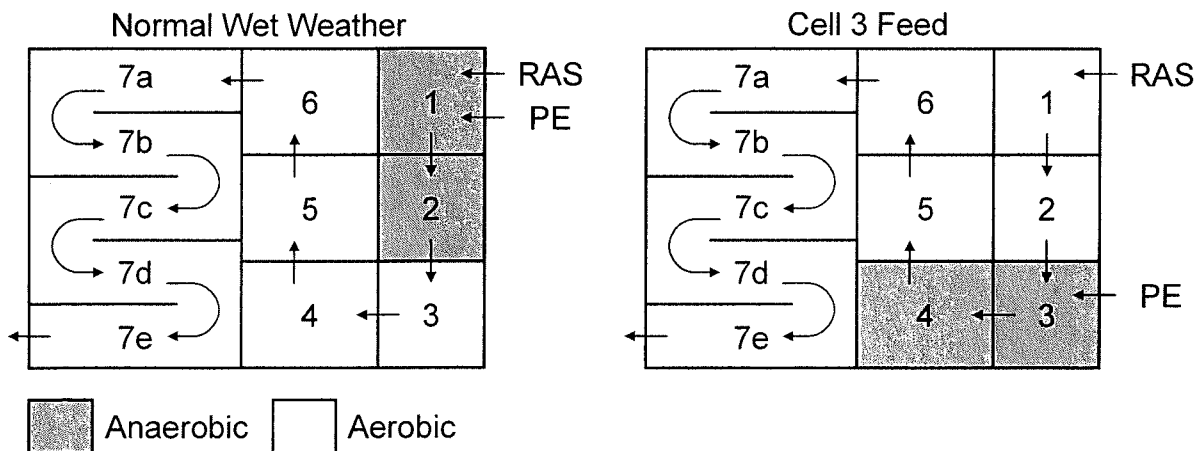

HIGH RATE WET WEATHER BIOLOGICAL CONTACT

Clean Water Services awarded CH2M HILL the Durham AWTF Facility Plan update. During this project, CH2M HILL noted that the existing basins appeared to have the capability to feed primary effluent (PE) directly to Cell 7, and operations staff confirmed this capability. This operating mode is shown in Figure 3. The plant has the option to operate Cells 1 and 2 in anaerobic mode to get some selector benefit during operation.

It was suggested that Operations staff consider testing the Cell 7 feed capability during a wet weather event (Wet Season 2005 – 2006). In late December 2005 and January 2006 plant flows reached an average daily flow of 76 MGD with peak day flows in excess of 80 MGD. Figure 4, 5, 6, and 7 shows the plant performance during this wet weather event for Aeration Basins 1, 2, 3, and 4 respectively. In general, these figures show excellent effluent TSS quality even at the highest wet weather flows when operating in the Cell 7 feed mode. The plant does not monitor BOD for each train; however, for the period where they were feeding Cell 7 feed the plant effluent CBOD₅ averaged 2.6 mg/L, just above the detection limit.

At the peak average day flow of 17 MGD to Aeration Basins 1 and 2 and feeding Cell 7, the PE had an average contact time of only 68 minutes. It should be noted that the maximum RAS rate for these basins was held at approximately 6 MGD. After solids had been redistributed, the Cell 7 MLSS values were approximately 1,000 mg/L. Aeration Basins 3 and 4 were fed at higher rates (peak average daily flow = 21 MGD) and showed similar performance at contact times of 58 minutes. As seen in these figures effluent COD was still low and actually less than the effluent COD's seen during average wet weather flows. This is most likely due to the dilution effect of the wet weather flows, but COD removal was still excellent since the influent CODs during wet weather events were all between 100 and 150 mg/L.

Figures 4 – 7 do show that starting into the Cell 7 feed mode can initially cause problems with secondary effluent TSS values. This is a result of the rapid transfer of solids from Cell 7 to the secondary clarifier, and the RAS system not being able to initially keep up with the load. Once the solids are transferred out of the secondary clarifier and are being stored in Cells 1 – 6 the performance of the secondary system goes back to normal. This illustrates the point that it is important to be able to gradually bring the Cell 7 feed mode into service so as to not overload the

Figure 3: Cell 7 Wet Weather Feed Mode

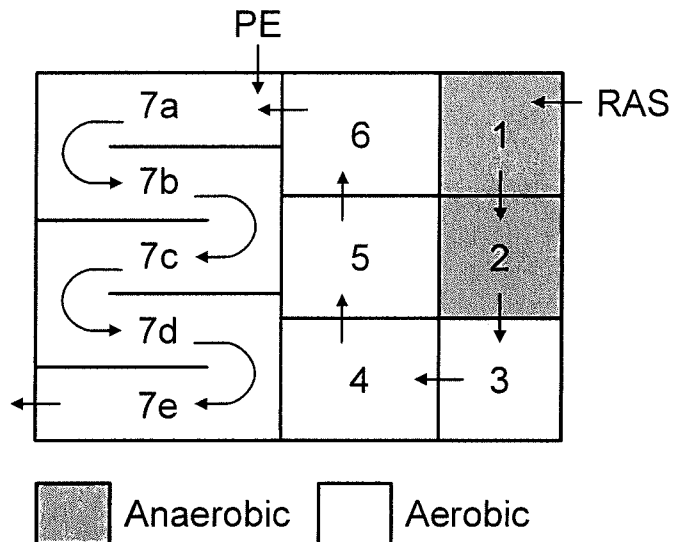

clarifiers while the solids are being redistributed within the secondary clarifier and aeration basin.

Figure 4: Aeration Basin 1 Wet Weather Performance

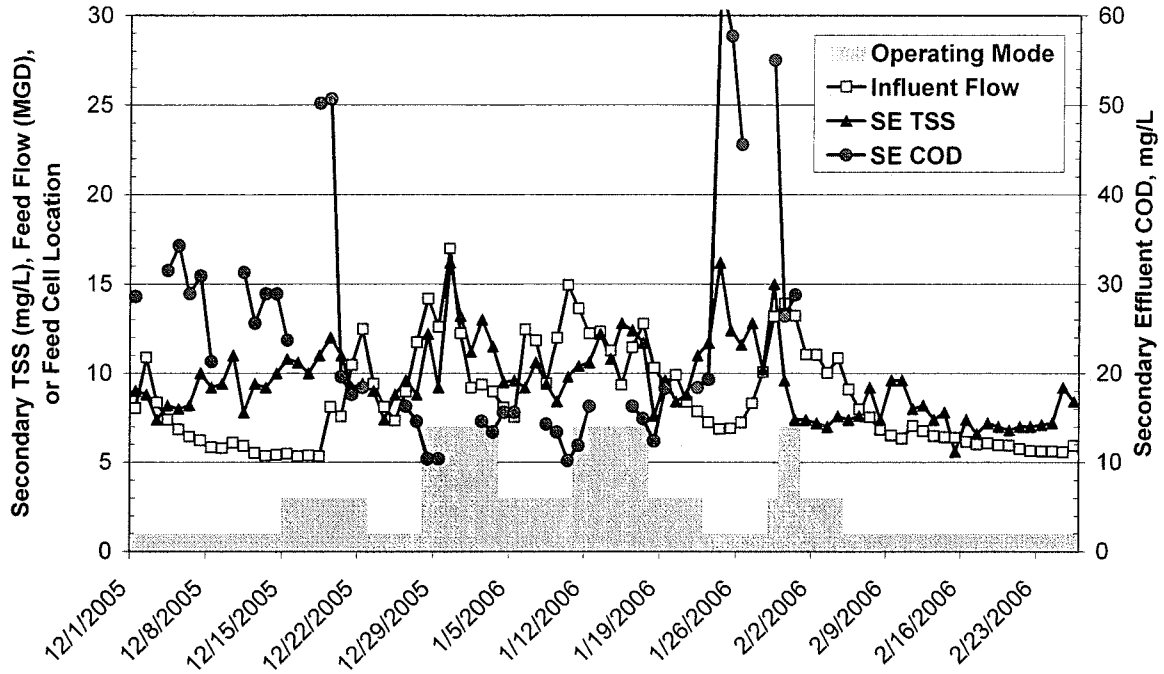

Figure 5: Aeration Basin 2 Wet Weather Performance

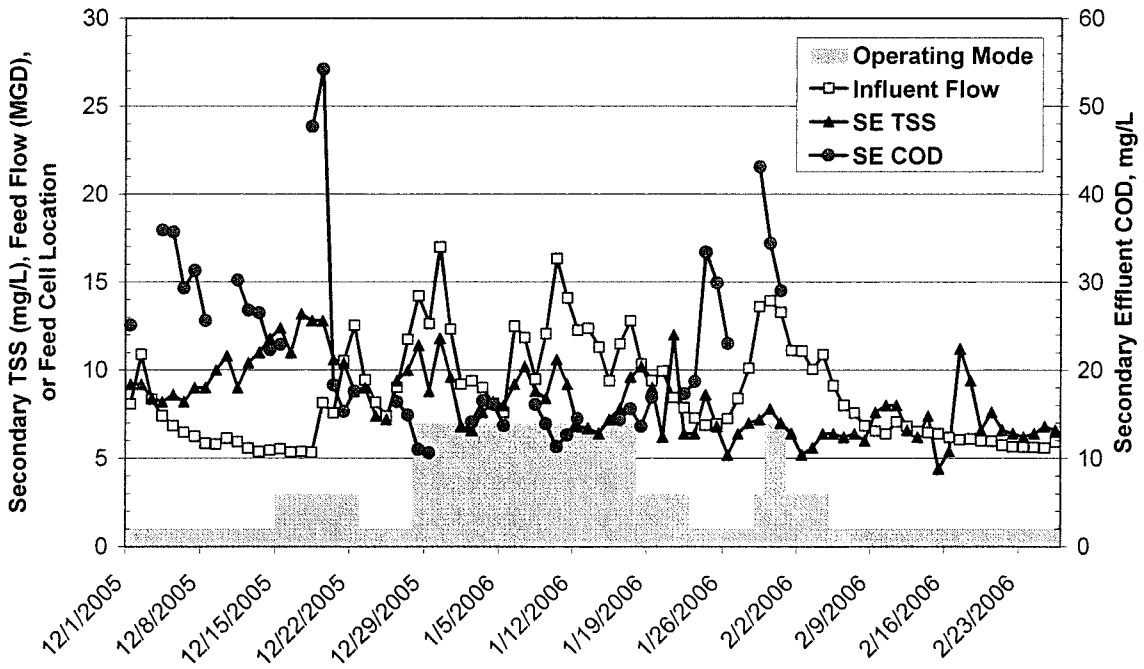

Figure 6: Aeration Basin 3 Wet Weather Performance

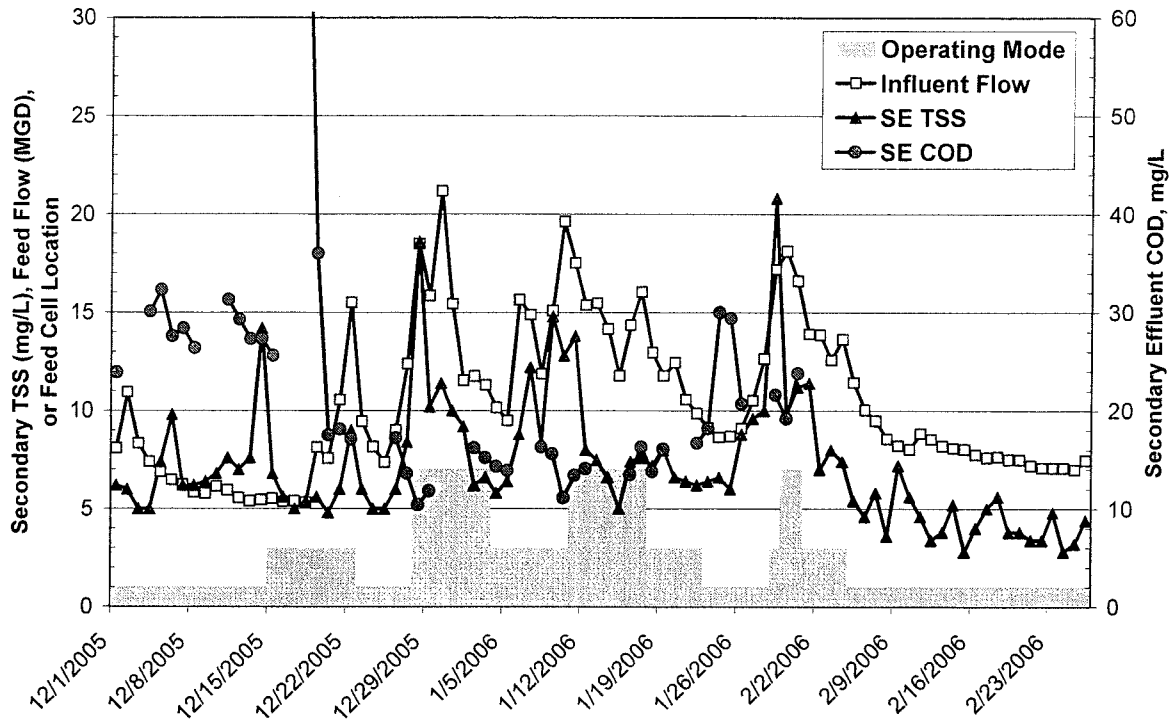

Figure 7: Aeration Basin 4 Wet Weather Performance

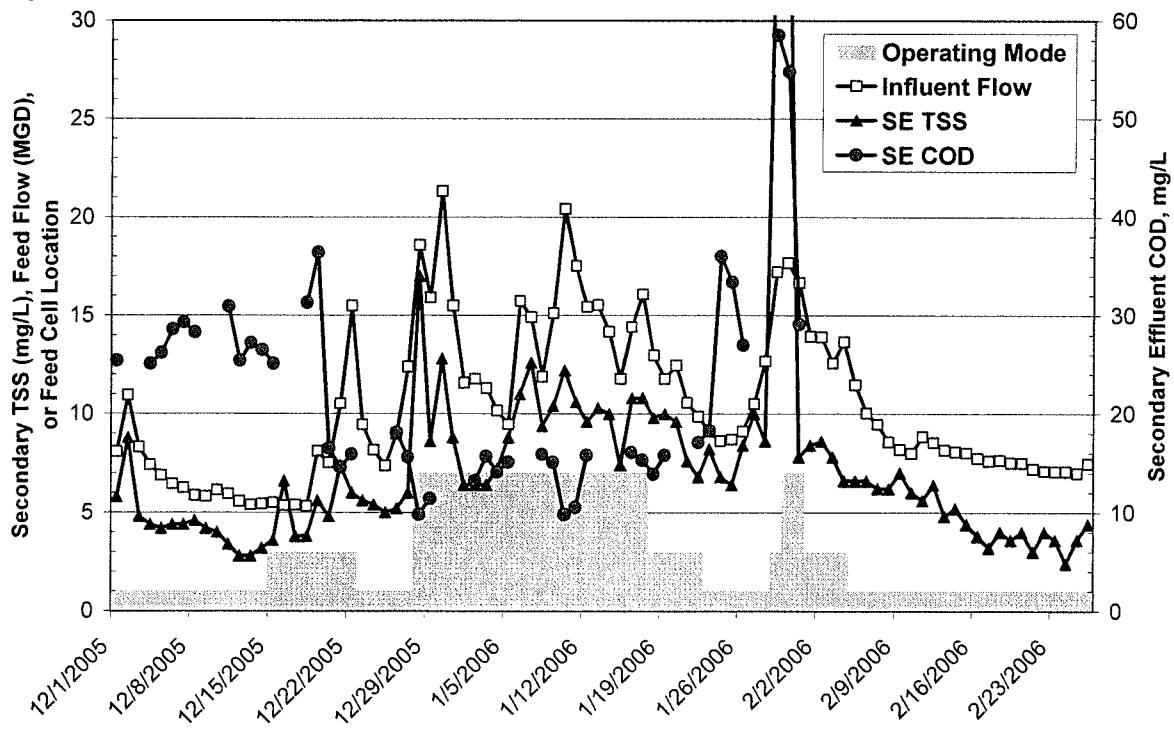

Figure 8 shows the whole plant performance during the 2006 -2007 wet season. Note that this performance is after filtration of the secondary effluent through granular media filtration. The graph shows excellent performance during the wet weather events with little to no increase in BOD during these events showing the effectiveness of the short contact time when operating in the Cell 7 feed mode.

Figure 8: Whole Plant Performance 2006 - 2007 Wet Season

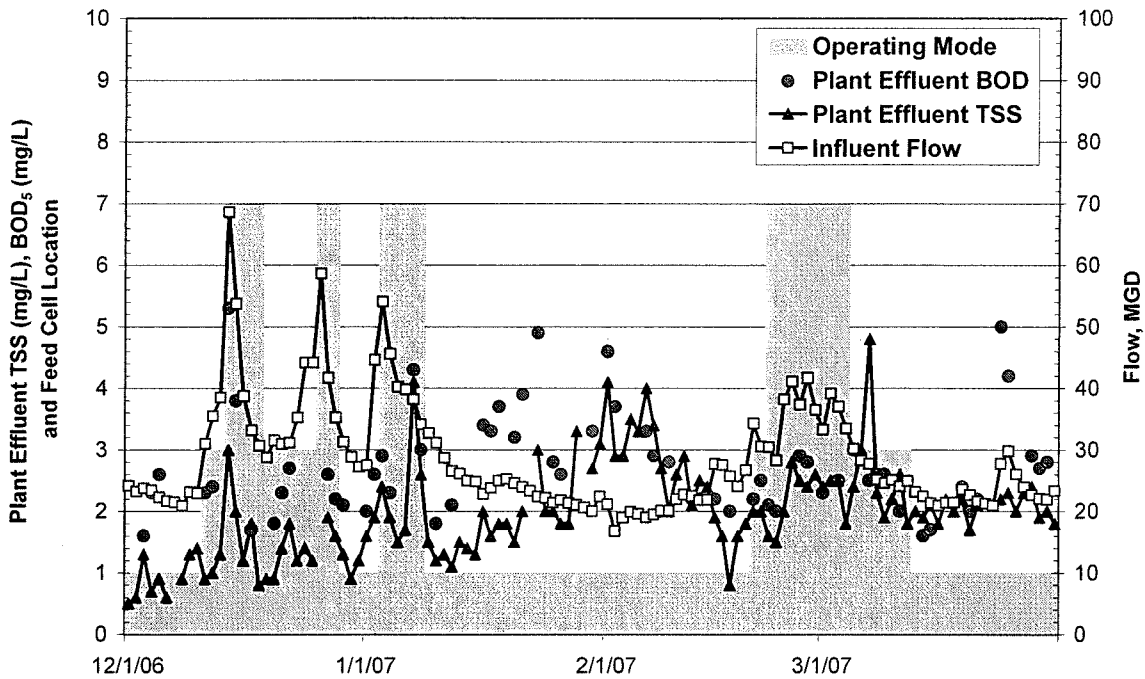
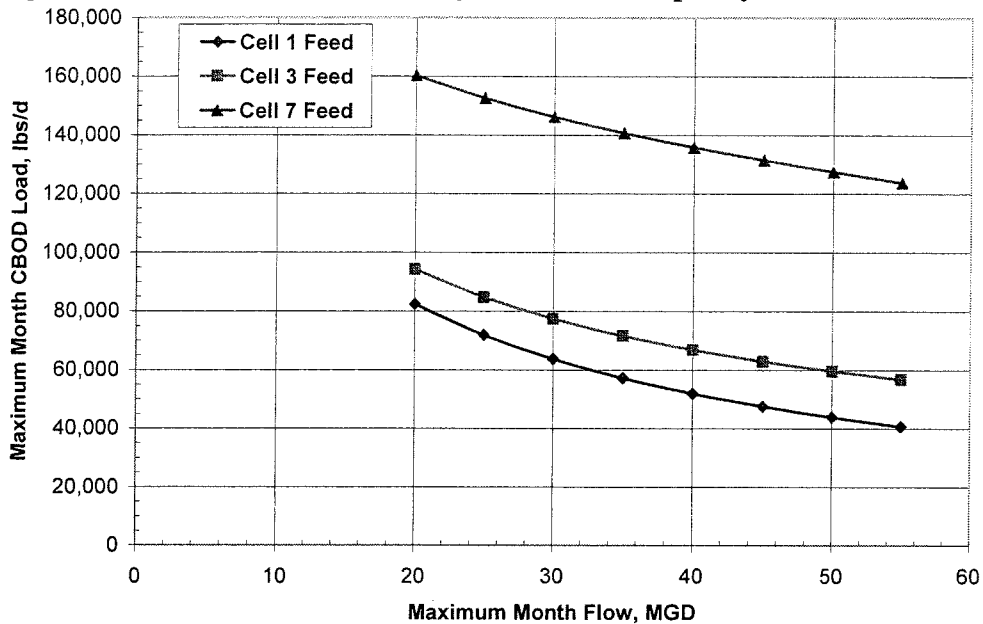

Figure 9 shows the capacity of the entire secondary treatment system when operating in the various feed modes. This graph accounts for maximum day flow events happening during the maximum month loading events, but equates the capacity to maximum month flows and loads. For Cell 1 and Cell 3 feed modes, as flow increases the capacity of the plant is eventually limited by the solids loading rate on the secondary clarifiers (as determined by flux theory). The Cell 7 feed mode eliminates that limitation, so the only limitation on the secondary clarifiers is the hydraulic loading rate, both from solids washout and from the hydraulic capacity of the piping in and out of the clarifiers.

Figure 9: Wet Weather Secondary Treatment Capacity



The use of the Cell 7 feed operating mode, allowed operations staff to provide full secondary treatment of their wet weather flows without using the surge basins for the entire 2005 - 2006 wet season for the first time in many years.

CONCLUSIONS

The performance of the Durham AWTF Cell 7 feed configuration confirms the ability of high rate wet weather biological contact to provide effective treatment of wet weather flows, without having to either equalize or blend with the primary effluent. With this operating mode, the only limitation on wet weather secondary treatment at the Durham AWTF is hydraulics, i.e. are the pipes and hydraulic structures large enough to handle the increased flows.

The contact times experienced during the peak flow events were approximately 60 minutes with MLSS levels in the contact zone of approximately 1,000 mg/L. This produced effluent BOD levels between 2 and 3 mg/L (near detection limits) during the wet weather events.

These results are directly applicable to the current research and interest in high rate biological contact for wet weather flows. These principals can be applied to existing secondary treatment systems needing to expand wet weather treatment capacity. These results are also applicable to independent high rate biological contact in that short HRT biological contact has been shown to be very effective at removing BOD from wet weather flows.

Effluent quality is very good when operating in the Cell 7 feed mode, but operational care must be taken when moving into this feed mode to avoid overloading the secondary clarifiers with the initial rush of solids from the aeration basin.

Figure 9 illustrates the wet weather secondary treatment capacity increase realized through the Cell 7 feed operating mode. At a primary influent BOD load of 60,000 lbs/day, the Cell 1 capacity is approximately 33 MGD, with Cell 3 feed it is approximately 50 MGD, and Cell 7 feed is only limited by the hydraulic overflow rate of the clarifier (currently estimated at 1,500 gpd/ft²), or approximately 100 MGD.



MSD

Louisville and Jefferson County
Metropolitan Sewer District

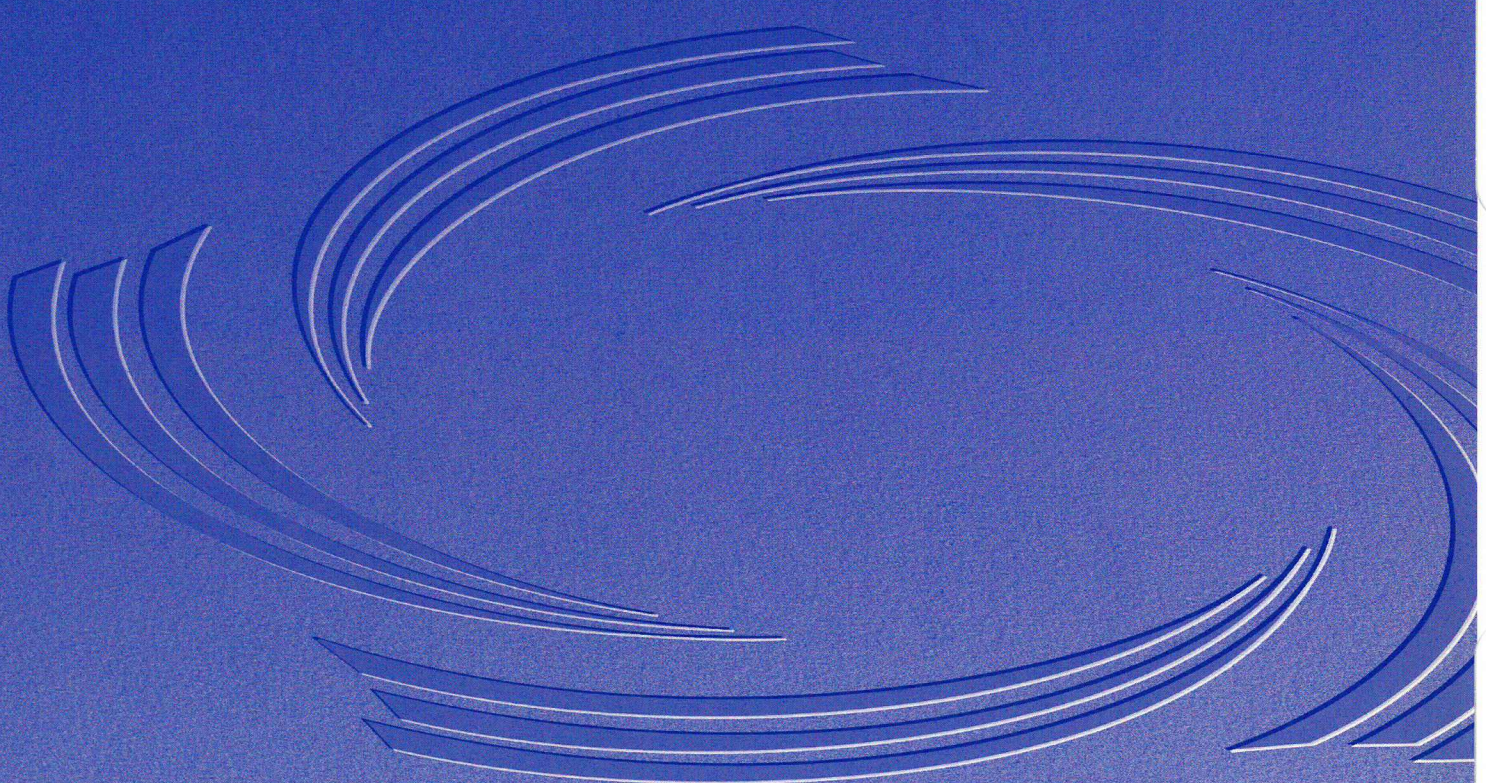

SECTION 3: IMPLEMENTATION PLAN

A Wet Weather Program (WWP) team, formed by the Louisville and Jefferson County Metropolitan Sewer District (MSD), will manage the planning, design and construction of the improvements needed to comply with the requirements of the Consent Decree. The WWP team is comprised of a dedicated staff of MSD employees and consultants.

The projects developed in the Interim Sanitary Sewer Discharge Plan (ISSDP) will be implemented by the WWP team and will be coordinated with projects developed as part of the Final Sanitary Sewer Discharge Plan (SSDP) and Long Term Control Plan (LTCP).

There are six major components of the implementation of the ISSDP, as follows:

- Beechwood Village
- Sinking Fork Relief Sewer
- Hikes Point and Highgate Springs Pump Station
- Southeast Diversion
- Northern Ditch Diversion Interceptor
- West County Wastewater Treatment Plant

3.1 PRELIMINARY CAPITAL COST ESTIMATES

The estimated capital cost to implement the ISSDP is approximately \$200 million, as summarized in Table 4. Some of the costs were estimated using a planning level cost estimating tool developed for projects associated with MSD's Wet Weather Plan. The remaining costs were developed by engineering firms under contract for either the planning or design of the respective project components. The capital costs include an allowance for items such as administration, contingencies, engineering, and inspection.

The costs are based on the Engineering News Record (ENR) Construction Cost Index for the midpoint of construction (November 2010) which is estimated to be 8550. The WCWTP costs were escalated from an earlier report cost estimate (ENR 8000) to 8550 to reflect the current project schedule. Costs developed herein are planning level costs based on multiple-cities' historical data, EPA documentation, and researched similar project data. The estimates prepared herein are based on best available data and judgments at the time they are developed. Estimates that are more detailed will be prepared as projects move to detailed design stages. These updated costs will continue to be monitored as the Integrated Overflow Abatement Plan is implemented.



TABLE 4		
ESTIMATED COST TO IMPLEMENT THE ISSDP		
PROJECT AREA	DESCRIPTION	COST
BEECHWOOD VILLAGE		
Beechwood Village System Improvements	Install 25,000 LF of New 8-inch Pipe Replace Existing 8-inch and 12-inch Pipes Replace 580 PSCs and Cleanouts Install 125 New Manholes	\$14,100,000
Sinking Fork Relief Sewer	Install 2000 LF of New 15-inch Pipe	\$1,800,000
TOTAL PROJECT CAPITAL COST		\$15,900,000
HIKES POINT & HIGHGATE SPRINGS PUMP STATION		
Hikes Lane Interceptor	Install 10,000 LF of New 72-inch Pipe Decommission Highgate Springs PS	\$28,900,000
Hikes Point Collection System	Install 2500 LF of New 21-inch Pipe	\$2,600,000
Carson / Ribble SSO Elimination	Install 1000 LF of New 15-, 18-, and 24-inch Pipe	\$200,000
TOTAL PROJECT CAPITAL COST		\$31,700,000
SOUTHEAST DIVERSION		
Southeast Diversion Modifications	Remove Weirs Re-program RTC gates	\$100,000
Southeastern Relief Interceptor	Install 3100 LF of New 36-inch Pipe Install Flow Control Junction Box	\$2,100,000
TOTAL PROJECT CAPITAL COST		\$ 2,200,000
NORTHERN DITCH DIVERSION		
Northern Ditch Diversion Interceptor	Install 13,000 LF of New 84-inch Pipe	\$24,700,000
TOTAL PROJECT CAPITAL COST		\$24,700,000
WEST COUNTY WASTEWATER TREATMENT PLANT		
High-rate Treatment	Construct 100 MGD Secondary Treatment	\$87,800,000
Pump Station Modifications	Expand from 80 MGD Firm to 291 MGD Firm	\$10,700,000
Screen / Concrete Basin	Construct 200 MGD with 30 min. Detention	\$20,400,000
Equalization Basin	Construct 36 MG Earthen Basin	\$3,100,000
TOTAL PROJECT CAPITAL COST		\$122,000,000
TOTAL SOLUTION COST		\$196,500,000

3.2 ISSDP PROJECT SCHEDULES

Most of the ISSDP projects are interdependent, so staging their implementation after construction is completed will be an important task. The projects and their sequence are shown schematically in Figure 12. In general, projects that capture more wastewater into the sanitary collection system that will ultimately reach the Pond Creek Interceptor and WCWTP cannot be implemented until other ISSDP projects downstream have been implemented. Hikes Point sewer improvements are in two different basins. The portion northwest of I-264 is discharged to the Goldsmith Lane Trunk Sewer which terminates at the Beargrass Interceptor. As a result, this part of the project is not dependent on the other components, and can be implemented independently of the other projects if needed.

Beechwood Village East and West collection systems will reduce wastewater flow by reducing infiltration and inflow, so these projects can be implemented independently of all other projects, except for the Sinking Fork Interceptor Relief Sewer. This relief sewer is currently planned to take the flow from some of the new Beechwood Village sewers, thereby freeing up capacity in the existing interceptor to accommodate future SSO elimination projects upstream. For this reason, the Sinking Fork Relief Sewer must be in operation before the Beechwood Village collection system improvements are completed and connected.

All other ISSDP projects must be implemented in sequence as shown in Figure 12. As shown in this diagram the following projects must be completed and implemented (e.g. become operational) in the following sequence:

1. WCWTP (first on-line, to receive additional flow from upstream projects)
2. Northern Ditch Diversion Interceptor (delivers the additional flow captured by upstream projects)
3. Southeastern Interceptor
4. Hikes Lane Interceptor

If any upstream project is completed prior to a downstream project it is dependent on, it will be connected and brought into operation after the downstream project is completed.

3.2.1 General

The schedules were prepared for each project's specific requirements as described below; however, activities common to all the projects are as follows:

3.2.2 Easements and Property Acquisitions

All six projects are anticipated to require easements and/or property acquisitions. In the most straightforward of projects, negotiating with property owners is a complex and often time-consuming process. The project schedules assume a time period of six months for preparing easements or plats, contacting and negotiating with property owners, and acquiring the property or easements. When owners are difficult to contact, or unwilling to negotiate or even communicate, the process can lengthen considerably. MSD's past experience suggests that if condemnation is required to acquire an easement or a property this process can add three to six months to the overall schedule. For some projects that have an unusually large number of owners or customers to contact, (e.g. Beechwood Village), or that may have a difficult property owner, (e.g. NDDI), additional time has been factored into this activity as further discussed below.

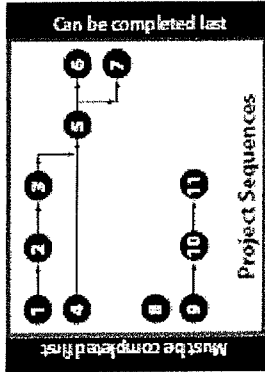
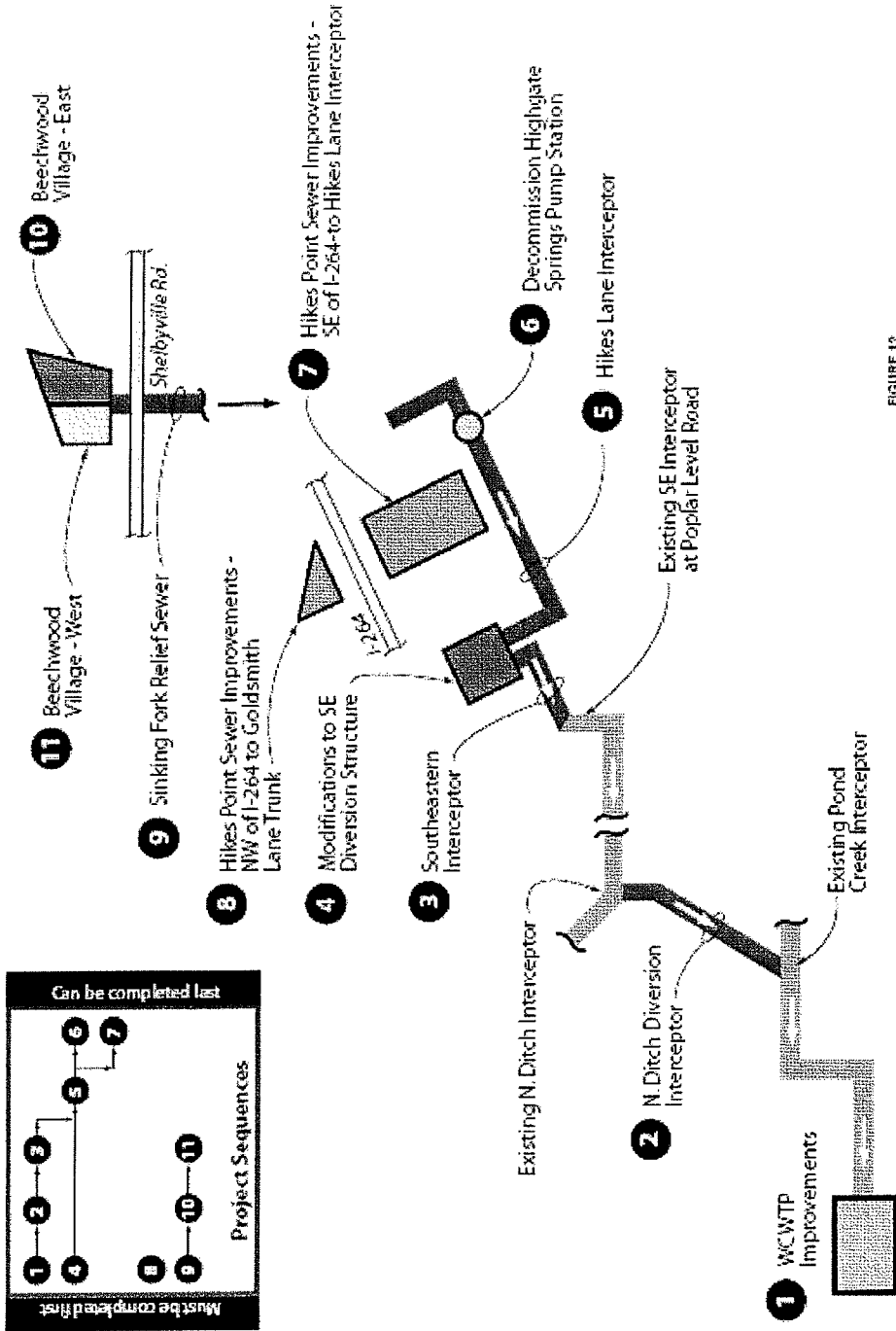

FIGURE 12
 Implementation Plan Schematic

CH2MHILL

FIGURE 12
 PROJECT SEQUENCE AND SCHEMATICS

3.2.3 U.S. Army Corps of Engineers (USACE) Permits

For projects that are expected to cross designated wetland areas and streams, a Clean Water Act (CWA) Section 404 permit will be required. A general (nationwide) permit is assumed to be sufficient for all projects based on the size of area impacted. Schedules were prepared based on a 6-month review and application processing period, and advertising for bids will not be initiated until the permit is obtained. If an individual permit would be required for any project, the time period for this activity could be considerably longer.

3.2.4 Kentucky Division of Water (KDOW) Construction Permit Review

All projects will require a KDOW construction permit. Applications for construction permits will be submitted to KDOW when the design drawings and contract documents are essentially complete. While this is referred to as "90%" complete on the schedule, this refers to MSD's payment milestone and not the level of completeness of the bidding documents. Schedules were prepared based on a 3-month review and permit processing period. One month is included in the schedule to allow for addressing KDOW comments and completing the final revisions to the bidding documents. Advertising for bids will not be initiated until the permit is obtained and the bid documents reflect KDOW comments. All schedules assume that only one review cycle will be required. If KDOW requires the design drawings and permit application to be resubmitted the project schedule will be lengthened.

3.2.5 Advertise, Bid and Award

Louisville and Jefferson County MSD procurement practices follow the provisions in Kentucky Revised Statutes 45A.345 – 45A.460. Advertising for bids must occur for at least 7 days, but typically extends up to 30 days for large and complex projects that require more bid preparation time. All projects included in the ISSDP are considered to be large enough to require a 30-day advertising period. At the appointed time sealed bids are opened and read. After bids are opened, then all bids are reviewed for any clerical or technical errors and for compliance with the contract documents and procurement regulations. After the review is completed a recommendation for award is presented to the MSD Board at the next scheduled Board meeting. After Board approval and Notice of Award is communicated to the successful bidder, the contractor must obtain certificates of insurance and other necessary documents before a Notice to Proceed can be issued. This entire process from the start of advertising until Notice to Proceed is issued typically requires 90 days.

A period of 90 days has been assigned to all projects for this activity. If there are any irregularities with bids such that the lowest, responsive and responsible bidder cannot be immediately identified and/or awarded the project, additional time would be required and the bidding process may even need to be repeated. Only one advertising and bidding cycle was assumed for each project, except for the Beechwood Village project, which will be bid in two parts (East and West Contracts) due to its size.

3.2.6 Project 1: Beechwood Village Sanitary Sewer Replacement (Exhibit 9)

This project consists of replacing 25,000 LF of 8-inch sanitary sewer system and service connections for 580 homes. The project will be split into two phases – East and West Contracts – to help ease project implementation. Consultant selection for design was completed in April 2007. Final design plans are substantially complete as of March 2008, pending completion of easement acquisition.

Easement surveying, negotiations, and acquisition are expected to require 270 days due to the need to obtain approximately 580 property owner's consent to a temporary easement for work to be done in their homes and for property service connection installation. This activity started January 2008 and is expected to be completed in September 2008. Although design of this project is straightforward, it cannot be finished until residential customer negotiations have been completed so that any special conditions required by customers can be input into the design contract documents. It is assumed that no temporary easements will have to be acquired through the condemnation process.

A USACE Section 404 permit is not anticipated for this project.

The KDOW permit application for construction will be submitted after final design is complete, while easement negotiations are underway. A 90-day period has been allocated for this task. Concurrently, 60 days has been assumed to address review comments in the contract documents to finalize design, which will occur while easement negotiations are being finalized. At this time in November 2008, advertising for bids will occur on the East Contract. Advertising for bids on the West Contract will occur 2 months later in January 2009.

The construction period was established at 24 months duration for each contract, based on the need to sequence pipeline installation with in-house plumbing modifications and service reconnection. The East Contract will start in March 2009 and be completed in February 2011. The West Contract will start May 2009 and be completed in April 2011.

3.2.7 Project 2: Sinking Fork Relief Sewer (Exhibit 10)

The need for this project was identified during the later stages of ISSDP development. This project is currently envisioned to consist of 2,000 LF of 15-inch pipe crossing Shelbyville Road to eliminate a hydraulic constriction. Continued work on the final SSDP has identified an opportunity to eliminate several other upstream SSOs if the project is modified to include diversion of current flows through a upsized pipes installed in Beechwood Village. Evaluations continue at the present time, and not final decision has been made on the inclusion of this upsized relief sewer through Beechwood Village.

Consultant selection for design was completed in December 2007. Preliminary design including route selection is underway and is currently scheduled to be completed in March 2008, subject to a potential change in scope as mentioned previously.

Immediately after preliminary design is completed all easement and topographic surveying will begin and will be completed before final design begins. This schedule will allow the design to continue and to be complete and ready for KDOW review in November 2008.

The interceptor route will require easements. A timeframe of 180 days has been allocated to negotiate and acquire the easements. Because this activity can be initiated early in design it will begin immediately after preliminary design is completed, but will require more time than final

design, so it will be critical path to the project schedule. It is assumed that no easements will have to be acquired through the condemnation process.

The KDOW permit application for construction will be submitted after final design is substantially complete. A 90-day period has been allocated for this task so the permit approval is expected by February 2009. After that, 30 days has been assumed to address review comments in the contract documents, and then advertising for bids will occur.

Because stream and wetlands crossings are not anticipated at this time, the USACE Section 404 permit application is not scheduled. If the alternate configuration mentioned above is chosen, stream and wetland crossings are likely. In this case the schedule for the Sinking Fork Relief Sewer will have to be revised to accommodate a Section 404 permit application, assumed to be available under the terms of the general permit. This requirement would impact the schedule, but is not likely to delay the completion of the Beechwood Village improvements, due to the long time required for easement acquisition in that project.

One public meeting is assumed to be held with neighborhood stakeholders to inform the public about the project and its impacts. The meeting will be held during the KDOW review so that comments in the meeting, if any, can be addressed when the design is finalized.

The construction period was established at 12 months duration for construction of the sewer plus an allowance for mobilization, shop drawing preparation and review, pipe and materials delivery, and project closeout. If the alternate configuration mentioned above is selected, the longer pipe route will extend the construction period to 18 months.

3.2.8 Project 3: Hikes Point Interceptor and Highgate Springs Pump Station (Exhibit 11)

This project consists of 10,000 LF of 72-inch interceptor, 3,500 LF of 15-, 18-, 21-, and 24-inch new and replacement sewers, and decommissioning of the HSPS. At least two stream crossings will occur. Construction on Hikes Lane will require partial closure of a busy street, which in turn will require Kentucky Transportation Cabinet (KTC) permitting. This permitting process is the largest unknown schedule factor in the ISSDP implementation. Given that the route of the pipeline is a state road, details of traffic control and construction easement restrictions will need to be agreed to. In MSD's past experience, these negotiations are often lengthy and may include limits on the times construction can occur, up to and including requiring all construction to be performed during the night. In addition to the time it takes to obtain the KTC permits, construction easement restrictions like this have the potential to drastically slow down construction.

Because of its review time requirement, a preliminary traffic analysis will be submitted for KTC review at the completion of preliminary design. The review is expected to require 6 months prior to initiating final design, so this activity will be critical path to the project schedule and is expected to be completed by April 2009. After this, final design will begin. At the midpoint in final design a permit application will be prepared and submitted to KTC. This review is expected to require three months to process and will be completed December 2009. The design contract documents will address all review comments and be finalized after this.

Consultant selection for design was completed in January 2008. Preliminary design including route selection, field investigations, geotechnical exploration, surveying, and utility research will be completed in September 2008. The geotechnical evaluation and report, 50 percent of the surveying and 50 percent of design are scheduled to be completed in September 2009. Design will continue and be completed in April 2010.



The USACE Section 404 stream crossing permits will also be applied for at the mid-point of final design so that a permit can be obtained near the completion of design and property acquisitions.

After design is completed contract documents will be submitted to KDOW for review such that approval is expected by July 2010.

The KDOW permit application for construction will be submitted after final design is substantially complete. A 90-day period has been allocated for this task. After that, 30 days has been assumed to address review comments in the contract documents, and then advertising for bids will occur.

All boundary, easement and topographic surveying will also be completed in September 2009, which will allow the easements and property acquisitions to start. The interceptor route and relief sewer falls on several properties that will require easements. A timeframe of approximately 6 months has been allocated to negotiate and acquire the easements. Because this activity can be initiated early in design, it can be completed at the same time as KDOW review is conducted. It is assumed that no easements will have to be acquired through the condemnation process.

One public meeting is assumed to be held with neighborhood stakeholders to inform the public about the project and its impacts. The meeting will be held during the KDOW review so that comments in the meeting, if any, can be addressed when the design is finalized.

The construction period was established at 24 months duration based on an average production rate of 40 LF per day for the 72-inch sewer, 80 LF per day for the intermediate size sewers, plus an allowance for mobilization, shop drawing preparation and review, pipe and materials delivery, pump station decommissioning, and project closeout.

3.2.9 Project 4: Southeast Diversion and Interceptor (Exhibit 12)

This project consists of 3,100 LF of 36-inch pipe, a flow control junction box, and modifications to the existing SED. Since this project is relatively minor and does not need to be in place until the Hike's Lane Interceptor is in place, consultant selection for design will begin October 2008. Preliminary design including route selection and surveying will be completed in August 2009. Final design including field investigations, geotechnical exploration, wetlands delineation, and utility research, will be completed in April 2010.

The interceptor route will require easements. A timeframe of 180 days has been allocated to negotiate and acquire the easements. Because this activity can be initiated early in design it can be completed before final design is completed. It is assumed that no properties will need to be procured through the condemnation process.

Because stream and wetlands crossings are not anticipated at this time, the USACE Section 404 permit application is not scheduled.

The KDOW permit application for construction will be submitted after final design is substantially complete and permit approval is expected in August 2010. A 90-day period has been allocated for this task. After that, 30 days has been assumed to address review comments to finalize the design contract documents, and then advertising for bids will occur.

One public meeting is assumed to be held with neighborhood stakeholders to inform the public about the project and its impacts. The meeting will be held during the KDOW review so that comments in the meeting, if any, can be addressed when the design is finalized.

The construction period was established at 18 months duration, based on an average production rate of 80 LF per day for a 36-inch sewer, construction of a new diversion structure and modifications to the existing structure, which will need to be performed in sequence, plus an allowance for mobilization, shop drawing preparation and review, pipe and materials delivery, and project closeout. The schedule shows construction finishing in August 2011. The main sewer will be complete in accordance with this schedule. However, the connections at the SED and the North Ditch Interceptor (NDI) cannot be completed until the WCWTP wet weather facilities are operational.

3.2.10 Project 5: Northern Ditch Diversion Interceptor Sewer (Exhibit 13)

This project consists of 13,000 LF of 84-inch pipe crossing probable designated wetlands and private properties where easements will be required. Consultant selection for design was completed in August 2007. Preliminary design including route selection was completed in October 2007.

Field investigations consisting of geotechnical exploration, wetlands delineation, and utility research, and final design were initiated in November 2007. Investigations for ecological studies were conducted and geotechnical work continued in December 2007. The geotechnical evaluation and report, 50 percent of the surveying and 30 percent of design are scheduled to be completed in March 2008.

All boundary, easement and topographic surveying will be completed in July 2008, which will allow the design to continue and be completed and ready for KDOW review in December 2008.

The interceptor route falls on 43 properties that will require easements. Among these easements is one industrial property owner that has historically been slow to respond to negotiations for easements. A timeframe of 270 days has been allocated to negotiate and acquire the easements. Because this activity can be initiated early in design it can be conducted before final design is completed. It is assumed that no easements or property will need to be acquired through the condemnation process.

Because of its time requirement, the USACE Section 404 permit will be applied for at the mid-point of final design so that a permit can be obtained near the completion of design and property acquisitions.

The KDOW permit application for construction will be submitted when final design is substantially complete. A 90-day period has been allocated for this task. After that, 30 days has been assumed to address review comments in the contract documents, and then advertising for bids will occur.

One public meeting is assumed to be held with neighborhood stakeholders to inform the public about the project and its impacts. The meeting will be held during the KDOW review so that comments in the meeting, if any, can be addressed when the design is finalized.

The construction period was established at 24 months duration based on an average production rate of 32 LF per day for 84-inch sewer, plus an allowance for mobilization, shop drawing preparation and review, pipe and materials delivery, special conditions for stream crossings, site restoration, and project closeout. The schedule shows construction finishing in July 2011. The main sewer will be complete in accordance with this schedule. However, the connections at the NDI and PCI cannot be completed until the WCWTP wet weather facilities are operational.

3.2.11 Project 6: West County Wastewater Treatment Plant Wastewater Flow Equalization and Treatment (Exhibit 14)

This project consists of a 100-mgd peak flow capacity secondary treatment facility, including expansion of the influent pump station, screening structure, and disinfection basins, and a new 36-MG equalization basin, all at the WCWTP site. Consultant selection for design was completed in November 2007.

Preliminary design for process selection and sizing, including field investigations for geotechnical exploration, wetlands delineation, and utility research, is underway and will be completed in August 2008. To maintain the required schedule, frequent communications with EPA and KDOW will be required during development of the preliminary engineering report. It is hoped that frequent communications on design concepts will result in a process selection that will meet with regulatory approval. The preliminary design report will be formally submitted to EPA and KDOW for approval of the approach to wet weather treatment upon completion in August. To keep the project on schedule, final design will be initiated during regulatory review of preliminary design report. Modifications in design parameters, if required, will be accommodated during final design development. By maintaining open communication during the preliminary design phase, it is hoped that major changes due to regulatory concerns can be avoided.

Completion of preliminary design will allow a USACE Section 404 permit application to be prepared, if needed for a second outfall. A waste load allocation and effluent limit request will also be submitted at the time final design begins. Because of its time requirement, the USACE Section 404 permit will be applied for at the beginning of final design so that a permit can be obtained near the completion of design.

Final design will be initiated in August 2008 and will reach the 50-percent milestone in February 2009. Design will continue and be completed in August 2009.

When design reaches the 50-percent milestone, outfall easements can be prepared, if needed. A period of 180 days has been assigned for easement acquisition so this activity will finish at the same time as final design.

One public meeting is assumed to be held with neighborhood stakeholders to inform the public about the project and its impacts, after the 50-percent design milestone is attained. The meeting and public notification process will occur over a 90-day period so that public feedback, if any, can be addressed before the design is finalized.

The KDOW permit application for construction and the KPDES permit application both will be submitted after final design is substantially complete. A 90-day period has been allocated for the construction permit. After that, 30 days have been assumed to address review comments and finalize the contract documents. Advertising for bids will then occur. A full 12 months has been assumed for processing the KPDES permit, so it will be obtained during construction, well in advance of the scheduled initiation of operations.

The construction period was established to provide two full warm-weather building seasons to reach substantial completion, allowing testing and start-up to be completed prior to the required completion date of December 31, 2011. The WCWTP wet weather facilities must be operational before upstream modifications can be complete. Construction and commissioning of the WCWTP wet weather flow equalization and wet weather treatment facilities are critical path to implementing the overall ISSDP.

3.3 Project Assessment

The primary goal of the ISSDP is to define a plan to eliminate unauthorized pumped discharges in Beechwood Village and Hikes Point, the elimination of the pumped discharge at the HSPS, and the closure of the constructed overflow at the SED. The efficacy of the proposed projects will be verified using three categories of post construction monitoring. The first category is the observation of the current overflow locations to confirm that overflows (pumped or otherwise) have in fact been eliminated. The second is flow monitoring within the collection system, to verify the predictions of the flow modeling. The third is the verification of full secondary treatment of all flows received at the WCWTP.

The most basic evaluation is the observations of the current overflow locations. In accordance with the Sewer Overflow Response Protocol (SORP), locations of interest will be monitored by visual inspection during significant wet weather events as part of the designated overflow observation routes. This procedure would continue for 3 years to confirm that the overflows have been eliminated.

Comparison of post construction flow monitoring to pre-construction flow monitoring will also be utilized as a validation of the projects efficacy. The post-construction flows should be consistent with the model predicted changes and design conditions. Post-construction monitoring using pre-construction metering sites when possible will produce the best results, allowing a fair test of project generated changes. Typical parameters to be measured include peaking factors, average daily flow, volume, and capacity ratio changes. This flow monitoring will be consistent with the overall post-construction flow monitoring plan to be developed as part of the final SSDP.

Lastly, verification of full secondary treatment of all flow through the West County WTP will be documented through start-up performance testing and continued monitoring of the effluent in accordance with the plant's KPDES permit. During start-up, performance testing will be conducted on the sidestream treatment process will confirm that all requirements of secondary treatment are met during wet weather operations. The specific testing plan will be developed based on the treatment process selected. This testing plan will be described generally in the Preliminary Engineering Report, and in more detail in the final Contract Documents issued for bidding. The Preliminary Engineering Report will be submitted to the EPA for review and approval of the intended preliminary design, including the secondary treatment process. To expedite the project schedule, design based on the Report's recommendations will be initiated while it is under review. If the KDOW or EPA require any revisions to the Report that would affect the design, the project schedule may be affected. Parameter measurements indicating adequate secondary treatment, including their collection and calculation procedure, will be clearly defined by the operating protocols discussed previously.



MSD

Louisville and Jefferson County
Metropolitan Sewer District

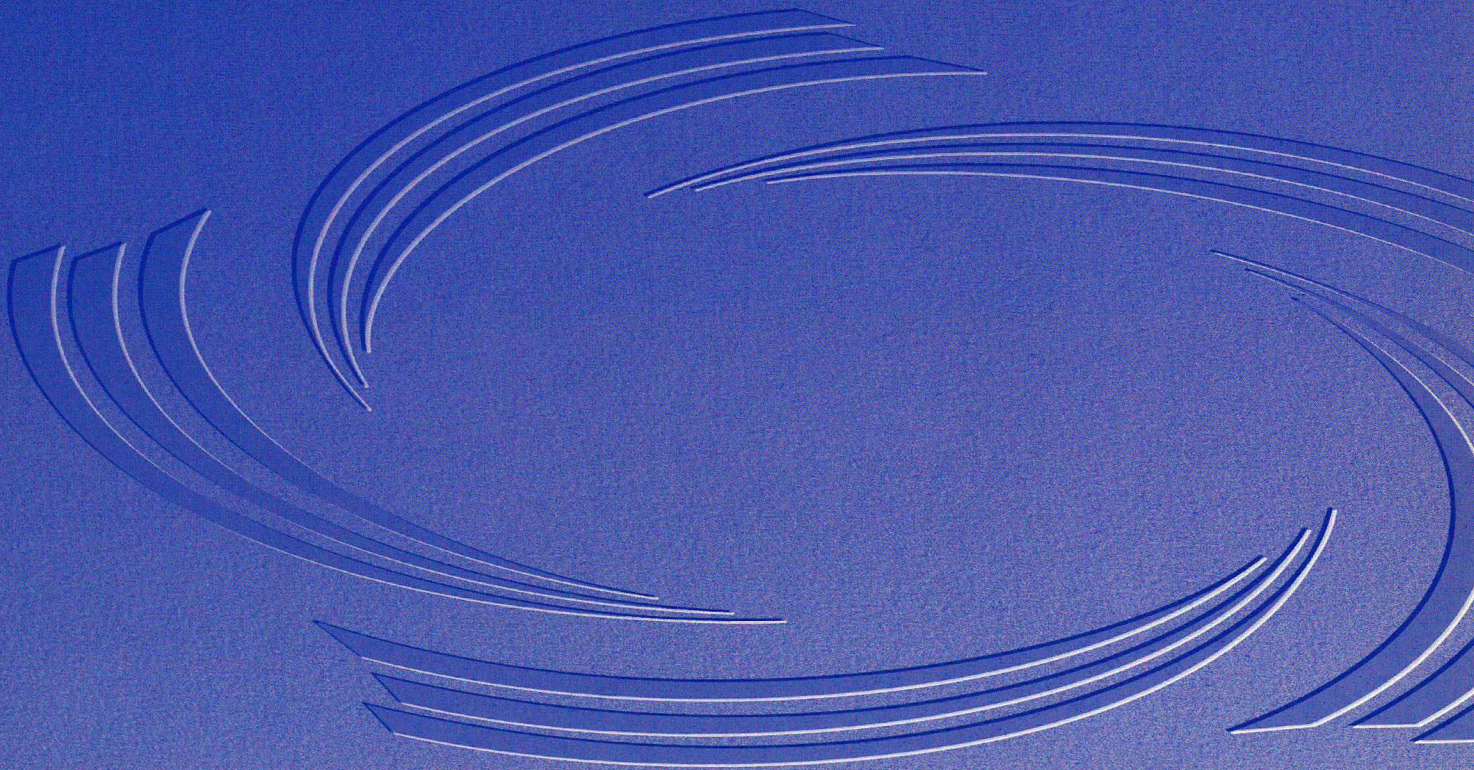



MSD

Louisville and Jefferson County
Metropolitan Sewer District

Interim Sanitary Sewer Discharge Plan (ISSDP)

March 8, 2008

EXHIBITS

- Exhibit 1: Targeted Unauthorized Discharge Locations
- Exhibit 2: Recommended ISSDP Solution
- Exhibit 3: Beechwood Village Area
- Exhibit 4: Highgate Springs Pump Station Area
- Exhibit 5: Hikes Point Area
- Exhibit 6: Southeast Diversion Structure
- Exhibit 7: Northern Ditch Area
- Exhibit 8: West County Wastewater Treatment Plant
- Exhibit 9: Beechwood Village System Improvements Schedule
- Exhibit 10: Sinking Fork Relief Sewer Schedule
- Exhibit 11: Hikes Pt. Interceptor and Highgate Springs PS Schedule
- Exhibit 12: Southeastern Diversion and Interceptor Schedule
- Exhibit 13: Northern Ditch Diversion Interceptor Schedule
- Exhibit 14: West County Treatment Plant Schedule

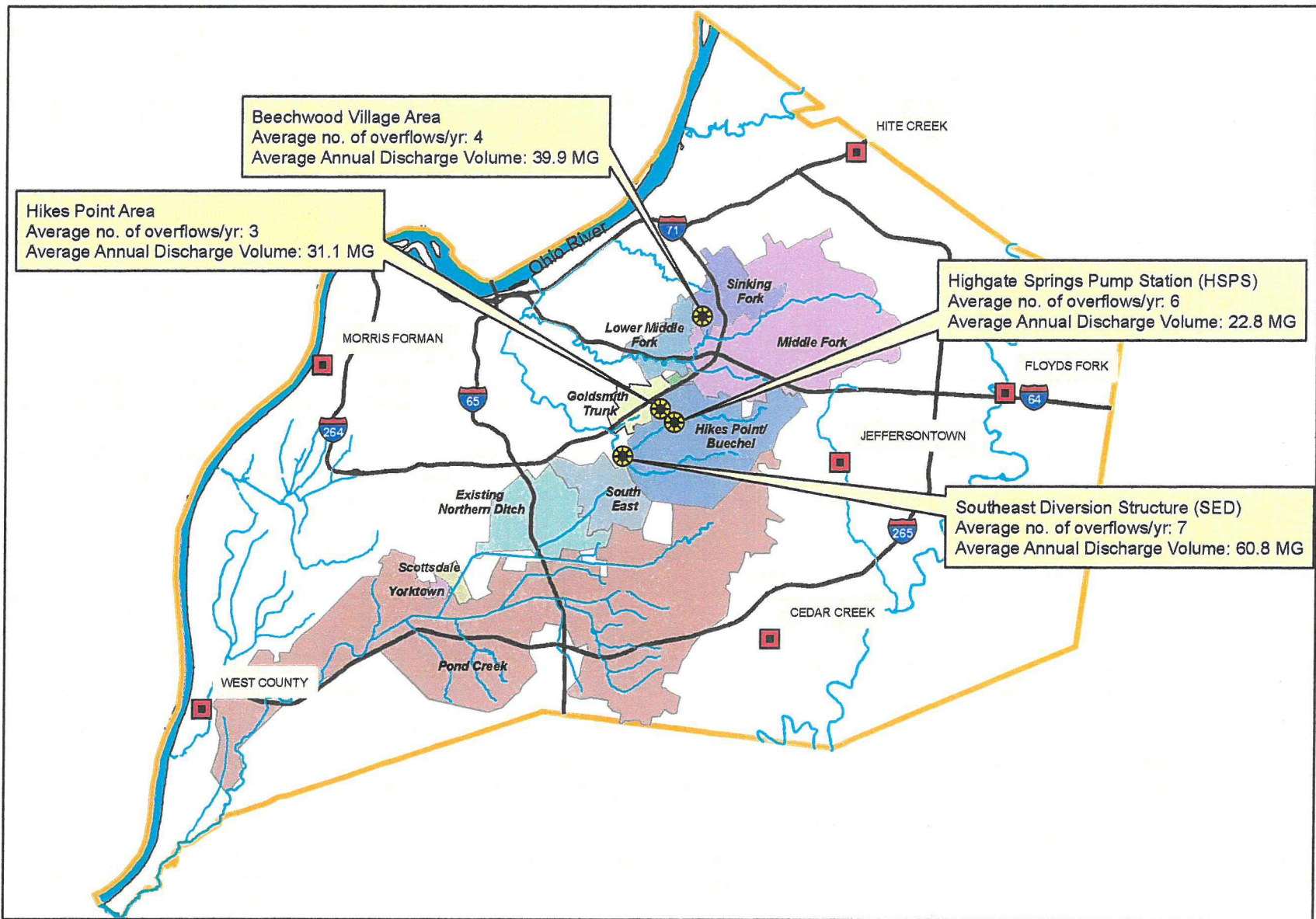

MSD



Exhibit 1: Targeted Unauthorized Discharge Locations



- Legend**
- Targeted Discharge
 - Major Stream
 - INTERSTATE
 - WTP
 - County Boundary

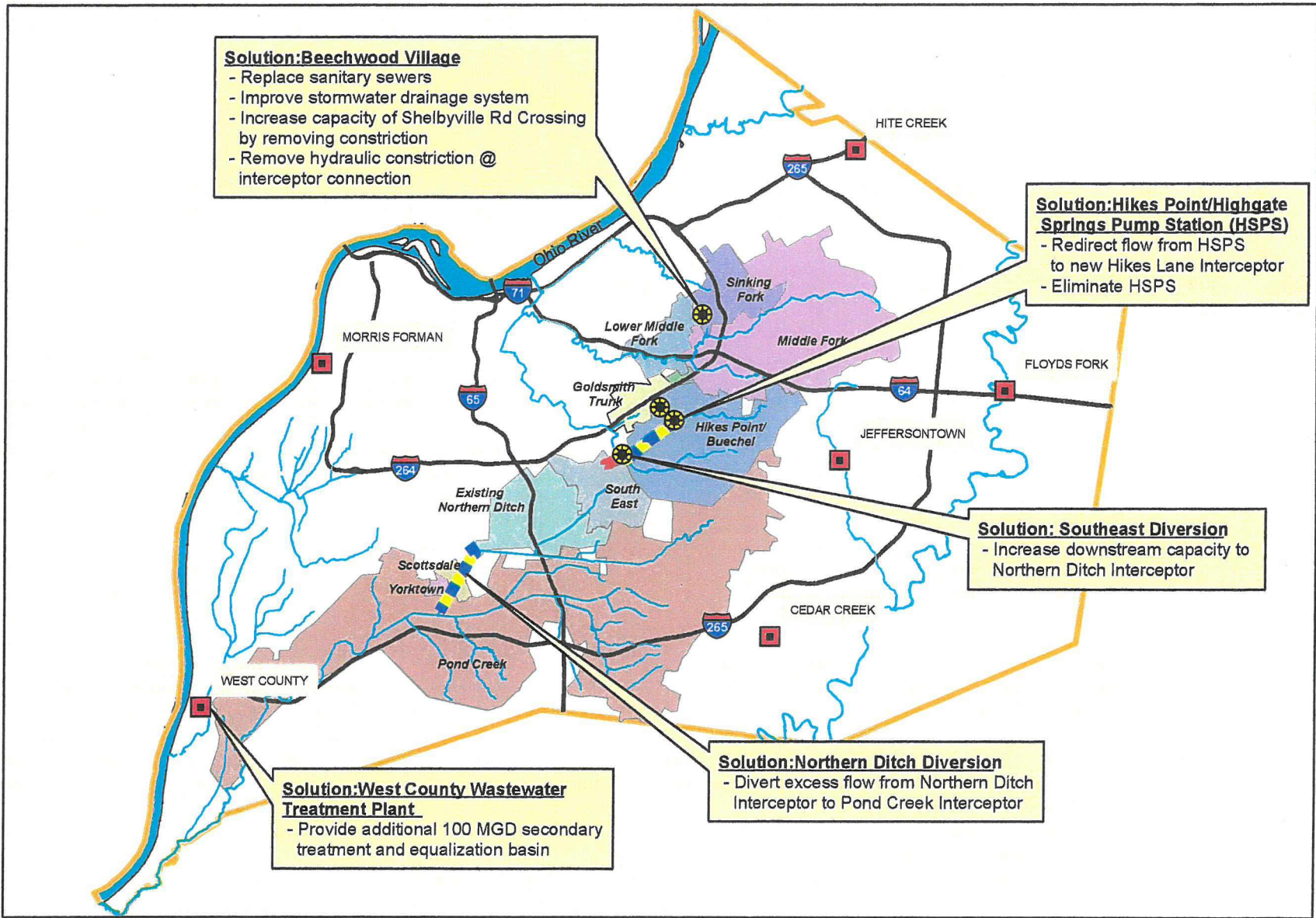

MSD



Exhibit 2: Recommended ISSDP Solution



Legend

- Targeted Overflows
- Major Stream
- INTERSTATE
- WTP
- County Boundary



Exhibit 3: Beechwood Village Area



Legend
 SSO Location
 Interstate
 Major Stream
 Sewers

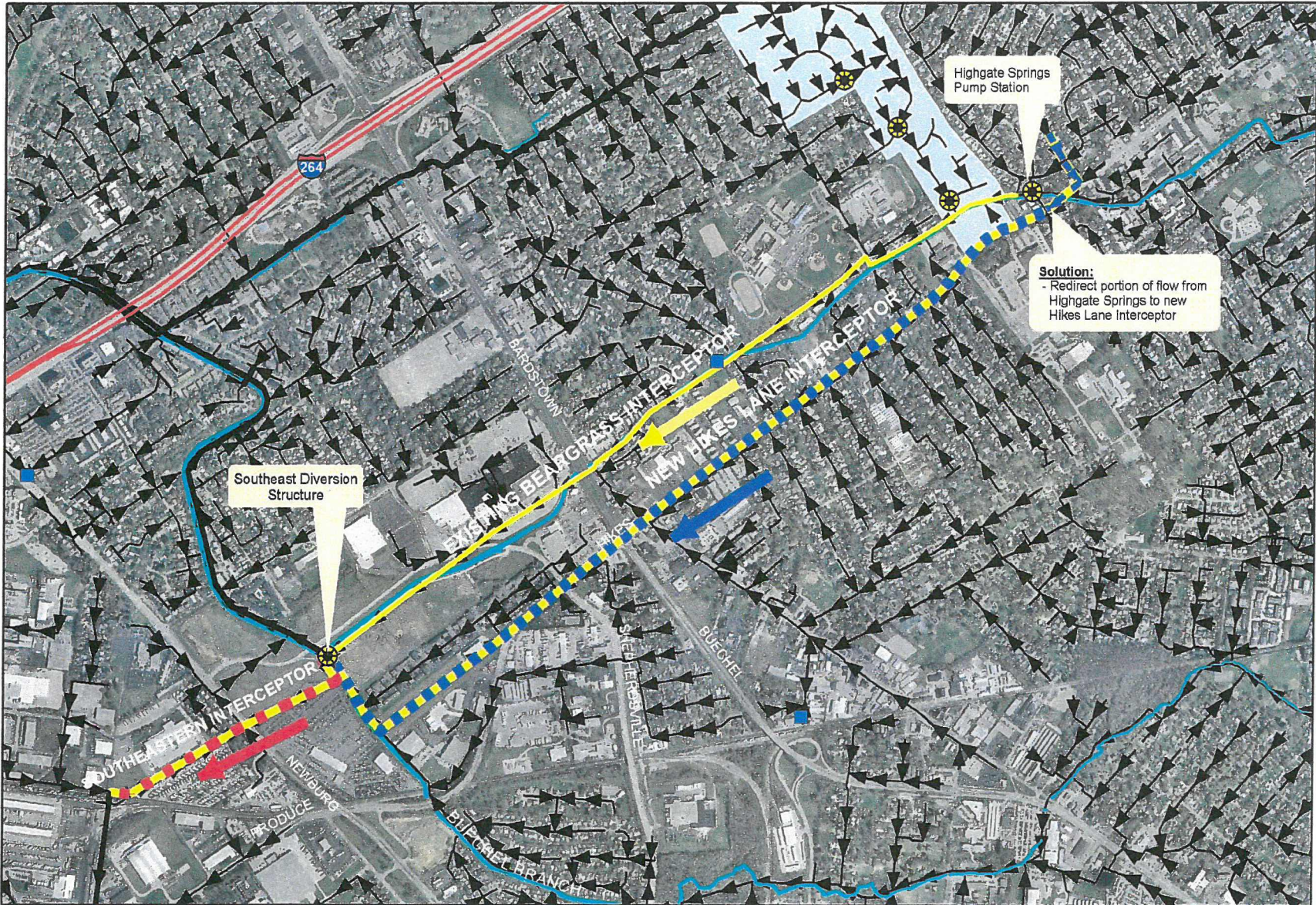

Exhibit 4: Highgate Springs Pump Station Area



- Legend**
- SSO Location
 - Major Stream
 - Hikes Point
 - Pump Station
 - Sewers
 - Interceptor
 - Interstate
 - Modify Existing Sewer
 - New Construction

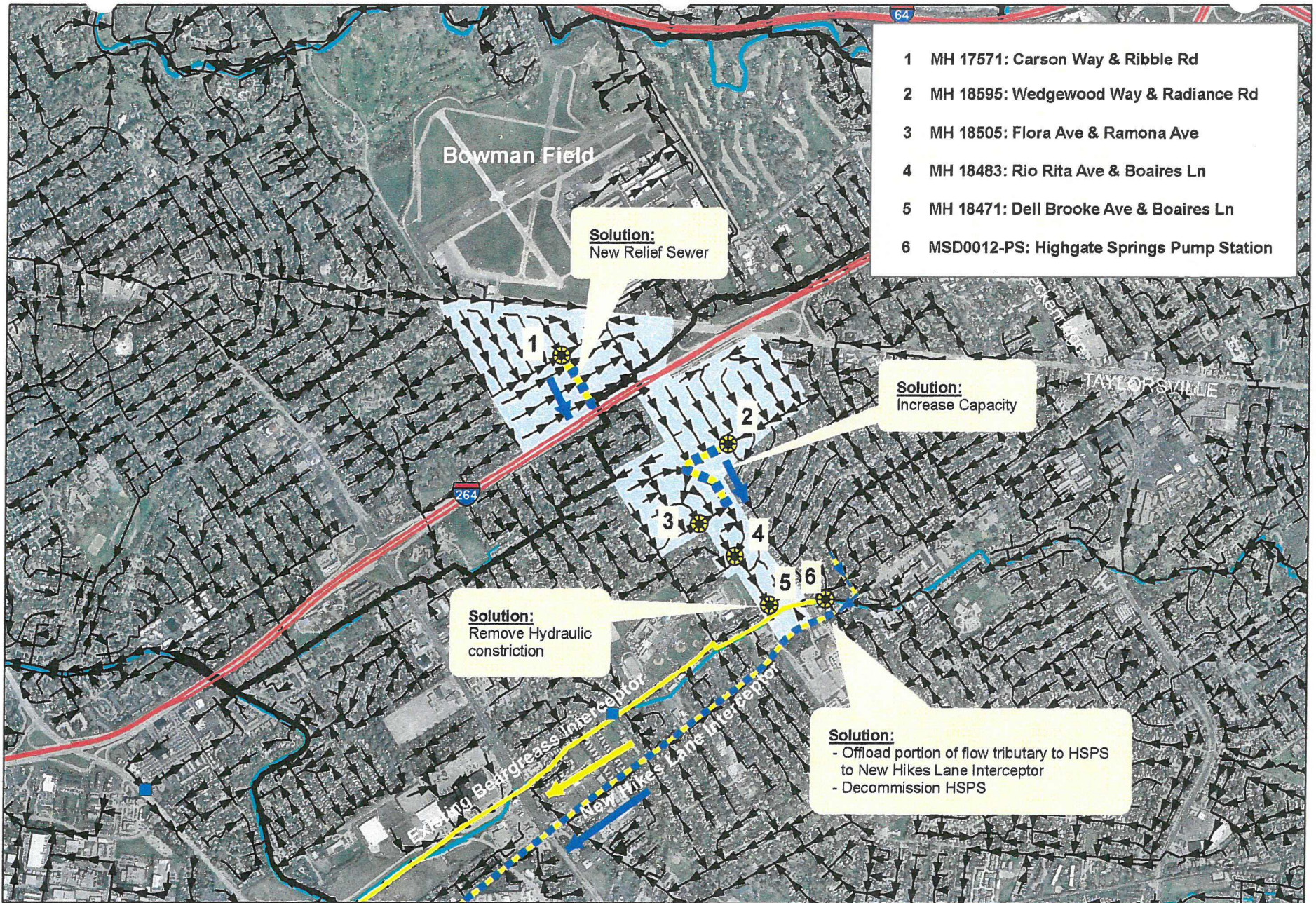

Exhibit 5: Hikes Point Area



Legend		

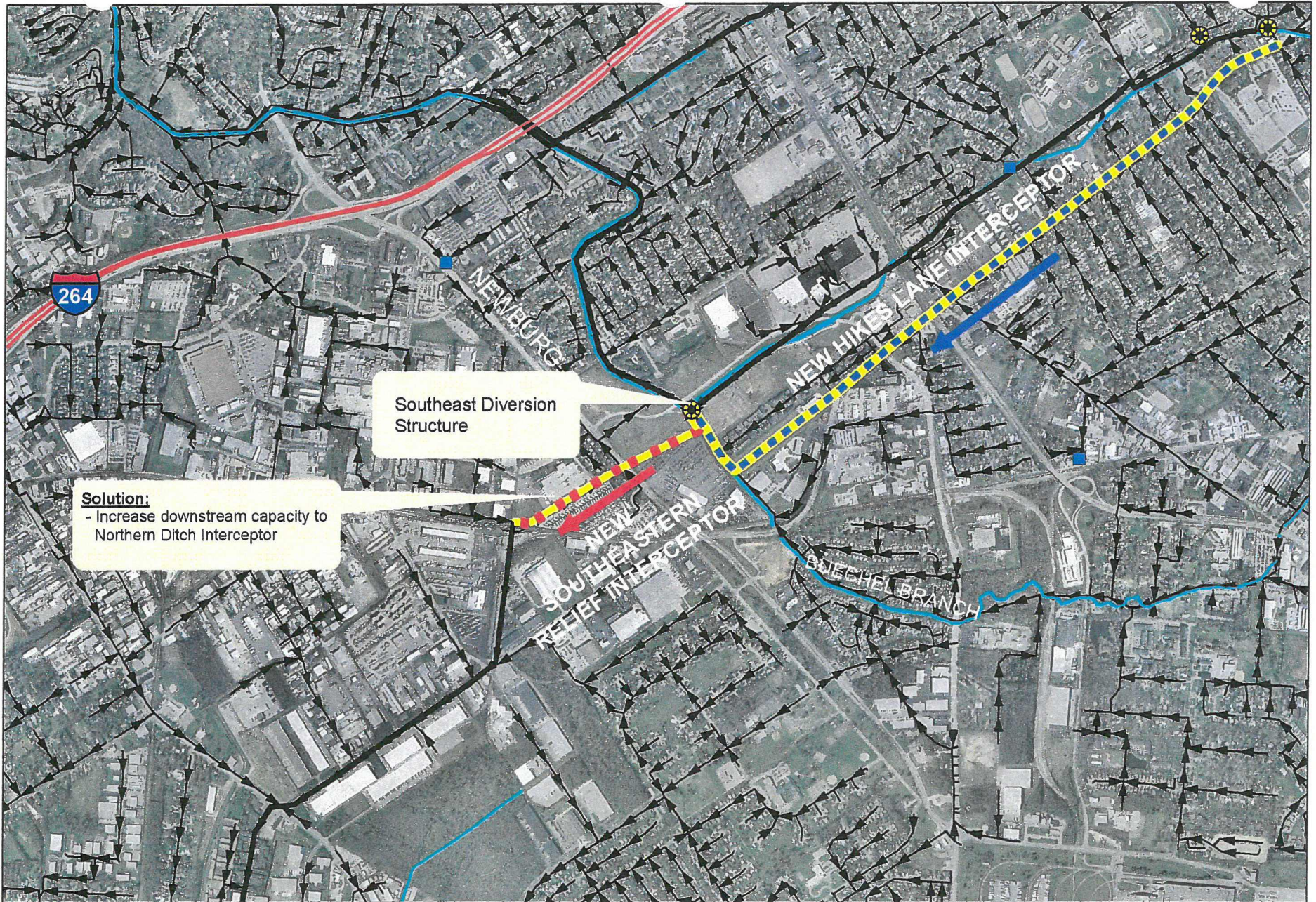

Exhibit 6: Southeast Diversion Structure



Legend	
	SSO Location
	Pump Station
	Modify Existing Sewer
	New Construction
	Major Stream
	Sewers
	Interstate

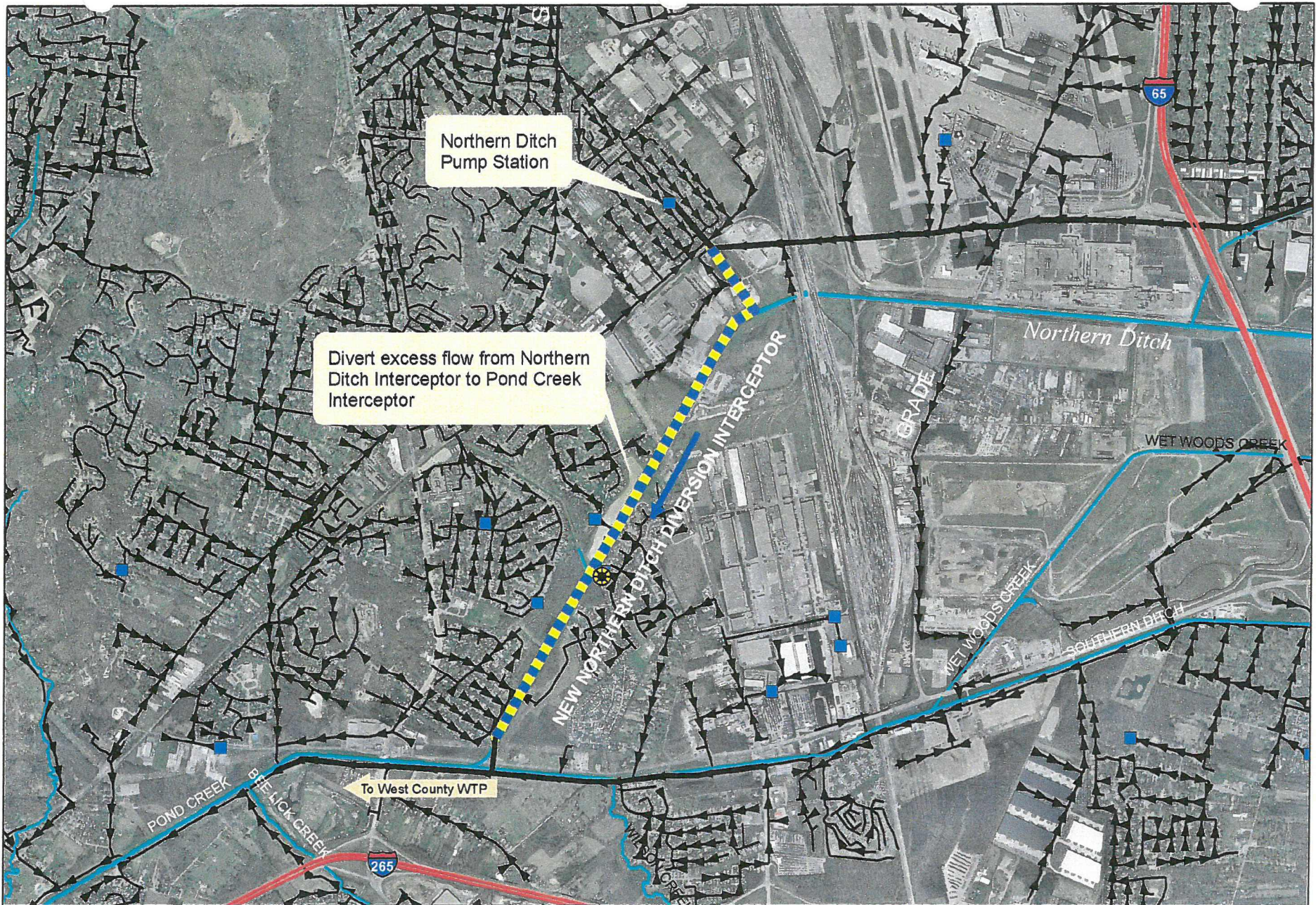



Exhibit 7: Northern Ditch Area



- Legend**
-  SSO Location
 -  Pump Station
 -  Major Stream
 -  Sewers
 -  New Construction
 -  Interstate

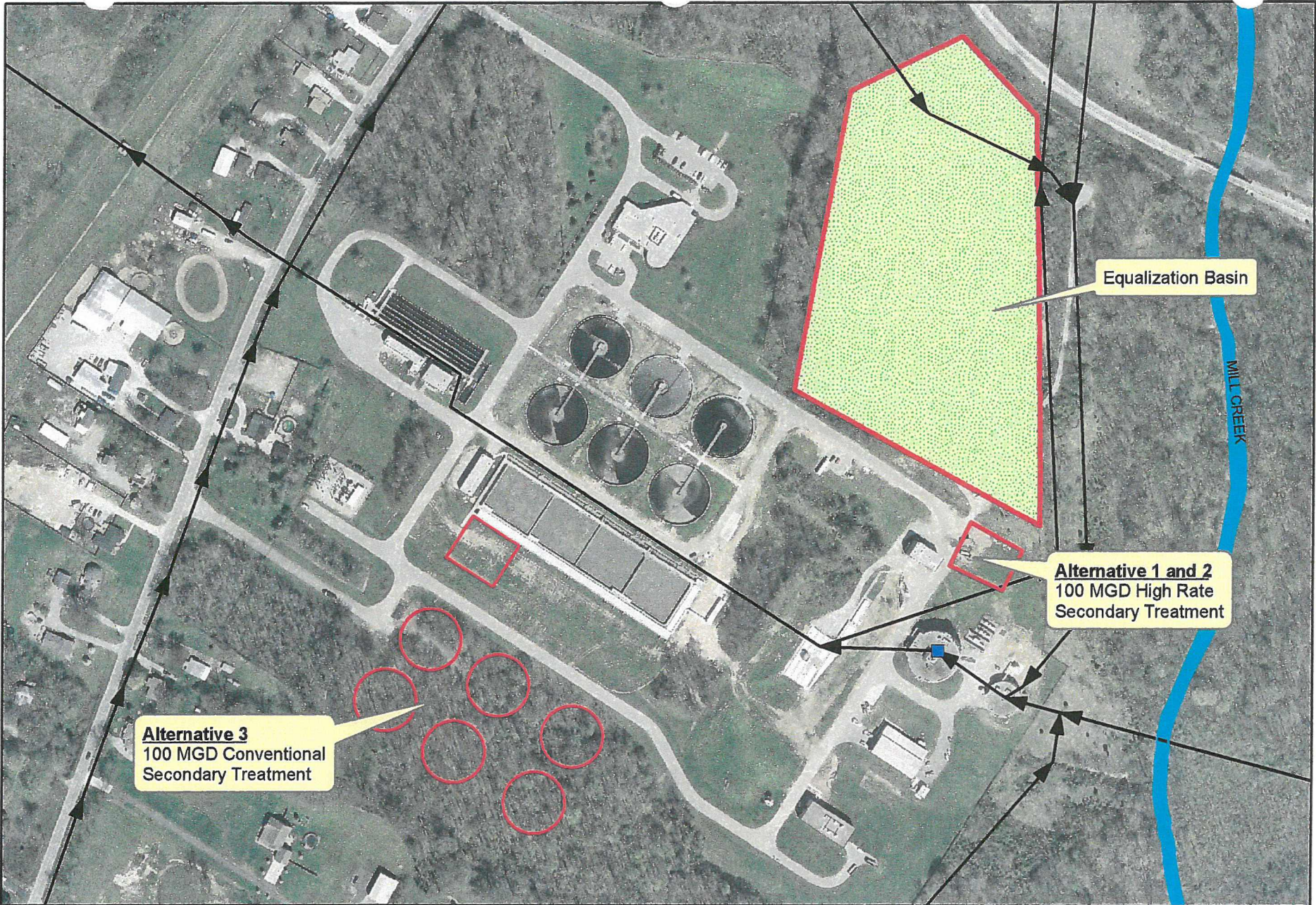

Exhibit 8: West County Wastewater Treatment Plant



- Legend**
- Pump Station
 - Major Stream
 - Sewers
 - Possible Storage Facility
 - New WTP Facilities

Exhibit 9 - Beechwood Village System Improvements

Activity Name	2007				2008				2009				2010				2011			
	Q1	Q2	Q3	Q4	Q1	Q2	Q3	Q4	Q1	Q2	Q3	Q4	Q1	Q2	Q3	Q4	Q1	Q2	Q3	Q4
A. Beechwood Village System Improvements	27-Apr-11																			
Consultant Selection, Scoping & Negotiation	[Gantt bar: Q1 2007 to Q2 2007]																			
Final Design - 90%	[Gantt bar: Q2 2007 to Q4 2007]																			
Easements & Property Acquisition	[Gantt bar: Q1 2008 to Q3 2008]																			
Construction Permit - KY DOW	[Gantt bar: Q3 2008 to Q4 2008]																			
Final Design - 100%	[Gantt bar: Q4 2008 to Q1 2009]																			
Advertise, Bid & Award - East Contract	[Gantt bar: Q1 2009 to Q2 2009]																			
Advertise, Bid & Award - West Contract	[Gantt bar: Q2 2009 to Q3 2009]																			
Construction - East Contract (Substantial Completion)	[Gantt bar: Q3 2009 to Q4 2010]																			
Construction - West Contract (Substantial Completion)	[Gantt bar: Q4 2009 to Q2 2011]																			



Exhibit 10 - Sinking Fork Relief Sewer

Activity Name	2007				2008				2009				2010				2011			
	Q1	Q2	Q3	Q4	Q1	Q2	Q3	Q4	Q1	Q2	Q3	Q4	Q1	Q2	Q3	Q4	Q1	Q2	Q3	Q4
B. Sinking Fork Relief Sewer																				
Scoping and Negotiations				█																
Preliminary Design				█																
Surveying & Easement Acquisition					█	█	█													
Final Design - 90%						█	█	█												
Public Meetings and Notification							█													
Construction Permit - KY DOW								█	█											
Review and Final Design - 100%									█	█										
Advertise, Bid & Award										█	█									
Construction													█	█	█	█				

30-Dec-10



Exhibit 11 - Hikes Point and Highgate Springs Pump Station

Activity Name	07	2008				2009				2010				2011				2012				2013				
	Q3	Q4	Q1	Q2	Q3	Q4	Q1	Q2	Q3	Q4	Q1	Q2	Q3	Q4	Q1	Q2	Q3	Q4	Q1	Q2	Q3	Q4	Q1	Q2	Q3	
C. Hikes Point Interceptor & High Gate Springs PS																										
Consultant Selection, Scoping, and Negotiation		■																								
Preliminary Design			■	■	■	■																				
KTC Preliminary Review						■	■	■	■																	
Design - 50%									■	■																
Final Design - 90%										■	■	■	■													
Easements & Property Acquisition										■	■	■	■													
Public Meetings and Notification										■	■															
KTC Permit										■	■															
Construction Permit - KY DOW												■	■													
Review and Final Design - 100%													■	■												
Advertise, Bid & Award														■	■											
Construction																■	■	■	■	■	■	■	■	■	■	■

27-Nov-12



Exhibit 12 - Southeastern Diversion and Interceptor

Activity Name	2008		2009				2010				2011				2012				
	Q3	Q4	Q1	Q2	Q3	Q4	Q1	Q2	Q3	Q4	Q1	Q2	Q3	Q4	Q1	Q2	Q3	Q4	
D. Southeastern Diversion & Interceptor																			31-May-12
Consultant Selection & NTP		█																	
Preliminary Design & Surveying			█	█	█														
Final Design - 90%					█	█	█	█											
Easements & Property Acquisition					█	█	█												
Construction Permit - KY DOW								█	█										
Public Meetings and Notification								█	█										
Review and Final Design - 100%									█	█									
Advertise, Bid & Award										█	█								
Construction												█	█	█	█	█	█	█	█

Exhibit 13 - Northern Ditch Diversion Interceptor

Activity Name	2007				2008				2009				2010				2011				2012
	Q1	Q2	Q3	Q4	Q1	Q2	Q3	Q4	Q1	Q2	Q3	Q4	Q1	Q2	Q3	Q4	Q1	Q2	Q3	Q4	Q1
E. Northern Ditch Diversion Interceptor	31-Jul-11																				
Consultant Selection, Scoping & Negotiations	■																				
Preliminary Design			■																		
Final Design - 90%				■	■																
43 Easements & Property Acquisition				■	■																
Site Assessments				■																	
Boundary and Topographic Surveys				■	■																
Permit - US ACE Section 404					■																
Construction Permit - KY DOW									■												
Public Meetings and Notification									■												
Review and Final Design - 100%									■												
Advertise, Bid & Award										■											
Construction											■										

Exhibit 14 - West County Treatment Plant

Activity Name	2007				2008				2009				2010				2011				2012				
	Q4	Q1	Q2	Q3	Q4	Q1	Q2	Q3	Q4	Q1	Q2	Q3	Q4	Q1	Q2	Q3	Q4	Q1	Q2	Q3	Q4	Q1	Q2	Q3	Q4
F. West County Treatment Plant																									
Feasibility Study	■	■																							
Consultant Selection and Negotiation		■	■	■	■																				
Preliminary Design					■	■	■	■	■																
Permit - US ACE Section 404 (Nationwide)								■	■	■	■														
WLA and Effluent Limit Request								■	■	■	■														
Design - 50%								■	■	■	■														
EPA / KYDOW Review and Approval								■	■	■	■														
Outfall Easements										■	■	■	■												
Public Meetings and Notification										■	■	■	■												
Final Design - 90%										■	■	■	■												
Construction Permit - KY DOW												■	■	■	■										
NPDES Permit Application												■	■	■	■	■	■								
Review and Final Design - 100%												■	■	■	■	■									
Advertise, Bid & Award													■	■	■	■									
Construction																■	■	■	■	■	■	■	■	■	■
Testing and Start-Up																								■	■

30 Dec 11

